

# ALPHA ALPHA SERIES Play A Decisive Role

Two post lift with floor connection



3500 KG

4500 KG



## ALPHA 35/45

Line Drawing

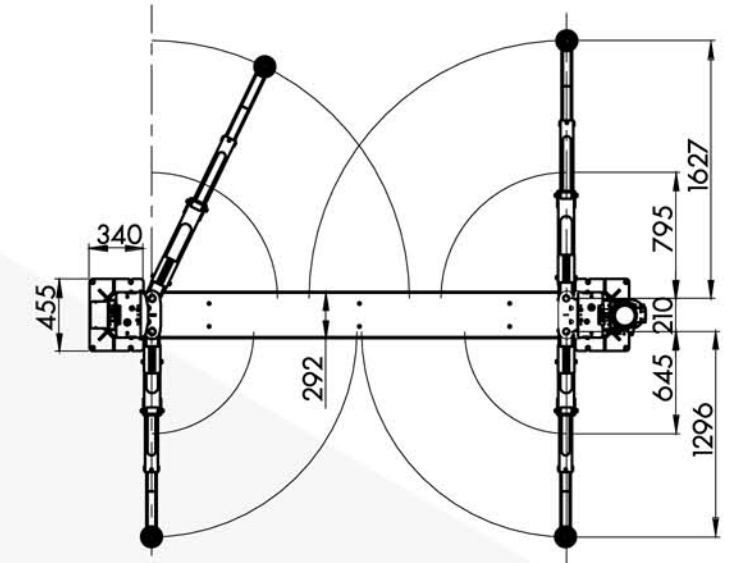
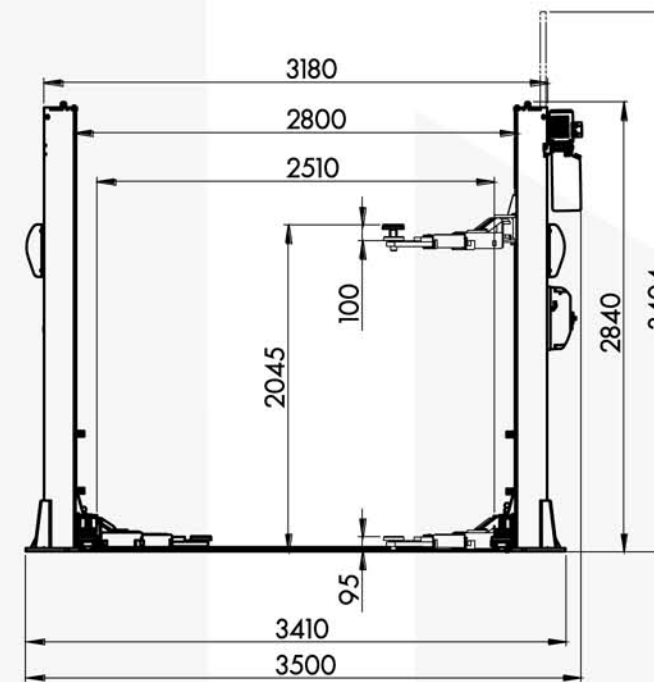

### Highlights

- Each group of main cylinders are equipped with a parachute valve to ensure safety. Nylon slide pads, long life-used, Maintenance free for its lifetime. The diameter of the cylinder craft is 50mm,3-year warranty.
- Environment-friendly and low noise design. The column adopts an 8-fold bending structure and built-in reinforcement to maximize the column strength. Unique electro locking system is designed without defect. The height of the carriage is 0.7 m. The door anti-collision rubber protection is put on the carriage and support arm to facilitate the entry and exit from the vehicle.
- Base plate thickness is 16/20mm; Vulcanized rubber pad has longer life. Equipped with switch protection for chain.
- Each lift passes the test of 115% dynamic load and 150% static load, safe and reliable.
- Bright's lift is equipped with product liability insurance



### Technical

	35	45
Capacity	3500kg	4500kg
Lifting time	40s	40s
Lowering time	40s	40s
Motor	380V 3kw 3Ph 50Hz-60Hz	380V 3kw 3Ph 50Hz-60Hz
Lifting height	2045mm	2045mm
Minimum height	95mm	95mm
Total width	3500mm	3500mm
Total weight	670Kg	750Kg