

GD100-2

Capacity 10.000 kg

FL60-2

Capacity 6.000 kg

FL160-2

Capacity 16.000 kg

GD150-2

Capacity 15.000 kg

FL90-2

Capacity 9.000 kg

FL200-2

Capacity 20.000 kg

GD200-2

Capacity 20.000 kg

FL120-2

Capacity 12.000 kg

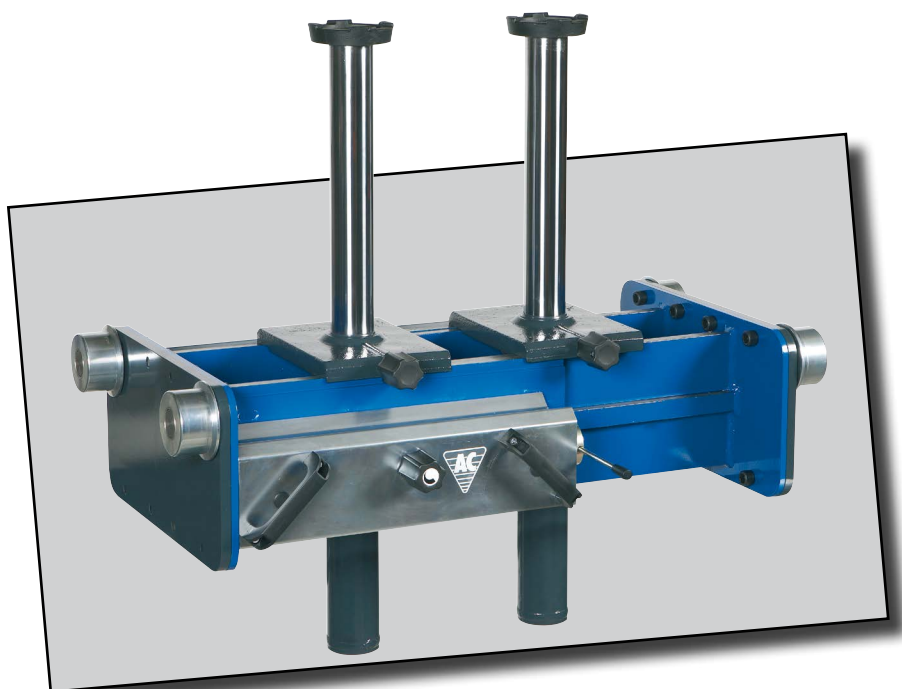

DK Brugermanual

Lufthydraulisk gravdonkraft / Frihjulsløfter

GB User's guide

Air-hydraulic Pit Jack / Heavy Duty Jacking Beam

DE Betriebsanleitung

Lufthydraulischer Grubenheber / Achsfreiheber



AC Hydraulic A/S

Fanøvej 6
DK-8800 Viborg - Danmark
Tel.: +45 8662 2166
Fax: +45 8662 2988
E-mail: ac@ac-hydraulic.dk
www.ac-hydraulic.com

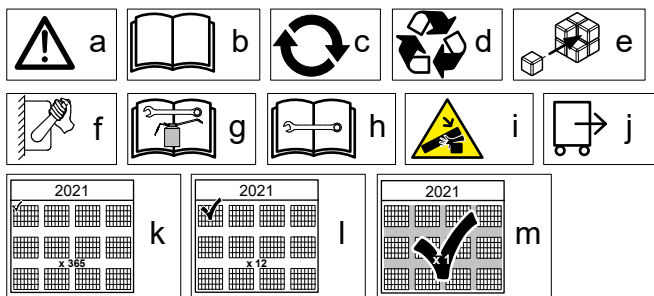

(DK) (NO) Original tekst

Produktbeskrivelse

Denne maskine er konstrueret med følgende komponenter:

- Løftecylindrer
- Pumpe enhed
- Betjeningspanel
- Olie tank
- Bærende struktur

Tilsligtet anvendelse

Denne maskine må kun anvendes til delvis løft af køretøj på en grav eller kørebanelift (Fig. 3).

Manualens formål

Denne manual indeholder følgende information:

- Sikkerhedsforanstaltninger og advarsler
- Maskinspecifikationer
- Samlevejledninger
- Betjeningsvejledninger
- Vedligeholdelse og servicevejledninger
- Sikkerhedseftersyn
- Fejlfinding
- Detaljerede tegninger og reservedelslister
- Hydraulik diagram
- Tilbehør
- CE Overensstemmelseserklæring

SYMBOLFORKLARING

- a** ADVARSEL! Risiko for alvorlig personskade eller dødsfald for brugeren eller andre. Vær forsigtig, og brug produktet korrekt
- b** Læs brugsanvisningen omhyggeligt igennem, og sørg for at have forstået vejledningen før brug af produktet (Fig. 1)
- c** Udskift beskadigede, slidte eller defekte dele
- d** Overhold de lokale krav til genanvendelse og de gældende regler.
- e** Montering
- f** Betjening
- g** Vedligehold
- h** Fejlfinding
- i** Klemningsfare
- j** Transport
- k** Daglig vedligehold
- l** Månedelig vedligehold
- m** Sikkerhedsmæssige eftersyn

(GB) Translation of original text

Product description

This machine has been built with the following components:

- Lifting cylinders
- Pump
- Control panel

- Reservoir
- Supporting structure

Intended use

This machine is only to be used for partly lifting vehicles in a pit or on a platform lift (Fig. 3).

Purpose of the manual

This guide contains or describes the next topics:

- Safe usage instructions and warnings
- Machine specifications
- Assembly
- Operation
- Maintenance
- Safety inspection
- Troubleshooting
- Detail drawings and spareparts
- Hydraulic diagram
- Accessories
- EC Declaration of Conformity for Machinery

KEY TO SYMBOLS

- a** WARNING! Be careful and use the product correctly. This product can cause serious injury or death to the operator or others.
- b** Please read the operator's manual carefully and make sure that you understand the instructions before use (Fig. 1).
- c** Replace damaged, worn or broken parts
- d** Obey the local recycling requirements and applicable regulations.
- e** Assembly
- f** Operation
- g** Maintenance
- h** Troubleshooting
- i** Crush hazard
- j** Transportation
- k** Daily maintenance
- l** Monthly maintenance
- m** Safety inspection

(DE) Übersetzung des Originaltextes

Produktbeschreibung

Diese Maschine wurde mit folgenden Komponenten gebaut:

- Hubzylinder
- Pumpe
- Bedienfeld
- Ölbehälter
- Unterstützende Struktur

Vorgesehene Verwendung

Diese Maschine darf nur zum teilweisen Heben von Fahrzeugen in einer Grube oder einem Fahrschiene-Hebebühnen (Fig. 3).

Zweck des Handbuchs

Dieses Handbuch enthält oder beschreibt die folgenden Themen:

- Sicherheitsvorschriften und Warnungen
- Maschinenspezifikationen
- Montage
- Bedienung
- Wartung
- Sicherheitsinspektion
- Fehlersuche und -behebung
- Detailzeichnungen und Ersatzteile

- Hydraulisches diagramm
- Zubehör
- EG Konformitätserklärung

SYMBOLERKLÄRUNG

- a** **WARNING!** Gehen Sie vorsichtig vor, und verwenden Sie das Gerät ordnungsgemäß. Dieses Gerät kann schwere oder tödliche Verletzungen des Bedieners oder anderer Personen verursachen.
- b** Lesen Sie die Bedienungsanleitung sorgfältig durch, und machen Sie sich vor der Benutzung mit dem Inhalt vertraut (*Fig. 1*).
- c** Ersetzen Sie beschädigte, abgenutzte oder defekte Teile.
- d** Befolgen Sie die örtlichen Recyclinganforderungen und geltenden Vorschriften.
- e** Montage
- f** Betrieb
- g** Wartung
- h** Fehlersuche und -behebung
- i** Quetschgefahr
- j** Transport
- k** Tägliche Wartung
- l** Monatliche Wartung
- m** Sicherheitsinspektion

(FR) Traduction du texte original

Description du produit

Cette machine a été construite avec les composants suivants:

- Vérins de levage
- Pompe
- Panneau de configuration
- Réservoir
- Structure de support

Utilisation prévue

Cette machine ne doit être utilisée que pour soulever partiellement des véhicules dans une fosse ou un élévateur à plate-forme (*Fig. 3*).

But du manuel

Ce guide contient ou décrit les sujets suivants:
Instructions d'utilisation et avertissements sécuritaires

- Spécifications de la machine
- Assemblage
- Utilisation
- Maintenance
- Inspection de sécurité
- Guide de dépannage
- Dessins de détail et pièces de rechange
- Schéma hydraulique
- Accessoires
- Déclaration CE de conformité pour les composants

EXPLICATION DES SYMBOLES

- a** **AVERTISSEMENT !** Soyez prudent et utilisez le produit correctement. Ce produit peut causer des blessures graves, voire mortelles, à l'opérateur ou à d'autres personnes.
- b** Veuillez lire attentivement le manuel d'utilisation et assurez-vous de bien comprendre les instructions avant utilisation (*Fig. 1*).
- c** Remplacez les pièces endommagées, usées ou cassées.
- d** Respectez les consignes locales de recyclage et la réglementation en vigueur.
- e** Montage
- f** Utilisation

- g** Maintenance
- h** Guide de dépannage
- i** Risque d'écrasement
- j** Transport
- k** Maintenance quotidienne
- l** Maintenance mensuel
- m** Inspection de sécurité

(SE) Översättning av originaltext

Produktbeskrivning

Denna maskin är byggd med följande komponenter:

- Lyftcylindrar
- Pump
- Kontrollpanel
- Tank
- Stödstruktur

Avsedd användning

Den här maskinen får endast användas för att delvis hissa upp fordon i en grop eller en plattformlyft (*Fig. 3*).

Syftet med manualen

Den här guiden innehåller eller beskriver följande ämnen:

- Instruktioner för säker användning och varningar
- Maskinspecifikationer
- Montering
- Drift
- Underhåll
- Säkerhetsunderhåll
- Felsökning
- Detaljritningar och reservdelar
- Hydrauliskt diagram
- Tillbehör
- EU Överensstämmelseförsäkran

SYMBOLFÖRKLARING

- a** **VARNING!** Var försiktig och använd produkten på rätt sätt. Den här produkten kan orsaka allvarlig eller livshotande skada för användaren och andra.
- b** Läs igenom bruksanvisningen noggrant och se till att du förstår instruktionerna innan användning (*Fig. 1*).
- c** Byt ut skadade, slitna och trasiga delar.
- d** Följ lokala återvinningsbestämmelser och tillämpliga förordningar.
- e** Montering
- f** Drift
- g** Underhåll
- h** Felsökning
- i** Krossfara
- j** Transport
- k** Dagligt underhåll
- l** Månatligt underhåll
- m** Säkerhetsunderhåll

(FI) Alkuperäisen tekstin käännös

Tuotekuvas

Tämä kone on rakennettu seuraavista komponenteista:

- Nostosylinterit
- Pumppu
- Ohjauspaneeli
- Säiliö
- Tukirakenne

Käyttötarkoitus

Tätä konetta käytetään vain ajoneuvojen osittaiseen nostamiseen kuoppaan tai lavanostimeen (Fig.3).

Käsikirjan tarkoitus

Tämä opas sisältää tai kuvaa seuraavia aiheita:

- Turvallisuusohjeet ja varoitukset
- Koneen tekniset tiedot
- Asentaminen
- Käyttö
- Kunnossapito
- Turvatarkastukset
- Vianmääritys
- Yksityiskohtaiset piirustukset ja varaosat
- Hydraulinen kaavio
- Lisätarvikkeet
- EU Vaatimustenmukaisuuvakuutus

MERKKIEN SELITYKSET

- a** VAROITUS! Ole varovainen ja käytä laitetta oikein. Tämä laite voi aiheuttaa käyttäjälle tai sivullisille vakavia vahinkoja tai kuoleman.
- b** Lue käyttöohje huolellisesti ja varmista, että ymmärrät sen sisällön, ennen kuin alat käyttää konetta (Fig.1).
- c** Vaihda vaurioituneet, kuluneet tai rikkoutuneet osat.
- d** Noudata paikallisia kierrätysvaatimuksia ja säädöksiä.
- e** Asentaminen
- f** Käyttö
- g** Kunnossapito
- h** Vianmääritys
- i** Murskausvaara
- j** Kuljetus
- k** Päivittäinen huolto
- l** Kuukausittainen huolto
- m** Turvatarkastukset

NL Vertaling van originele tekst

Productbeschrijving

Deze machine is gebouwd met de volgende componenten:

- Hefcilinders
- Pomp
- Bedieningspaneel
- Reservoir
- Ondersteunende structuur

Gebruiksdoeleinden

Deze machine mag alleen worden gebruikt voor het gedeeltelijk heffen van voertuigen in een put of een platformlift (Fig.3).

Doel van de handleiding

Deze gids bevat of beschrijft de volgende onderwerpen:

- Instructies voor veilig gebruik en Instructies
- Machine specificaties
- Assemblage
- Werking
- Onderhoud
- Inspectie van de veiligheid
- Storingzoeken
- Detailtekeningen en onderdelen
- Hydraulisch schema
- Accessoires
- EU Verklaring van overeenstemming

VERKLARING VAN DE SYMBOLEN

- a** WAARSCHUWING! Wees voorzichtig en gebruik het product op de juiste manier. Dit product kan ernstig of fataal letsel toebrengen aan de gebruiker of anderen.
- b** Lees de bedieningshandleiding zorgvuldig door en zorg dat u de instructies hebt begrepen voordat u het product gebruikt (Fig.1).
- c** Vervang beschadigde, versleten of defecte onderdelen.
- d** Neem de plaatselijk geldende wet- en regelgeving voor recycling in acht.
- e** Montage
- f** Werking
- g** Onderhoud
- h** Storingzoeken
- i** Gevaar voor beknelling
- j** Vervoer
- k** Dagelijks onderhoud
- l** Maandelijks onderhoud
- m** Inspectie van de veiligheid

ES Traducción del texto original

Descripción del producto

Esta máquina ha sido construida con los siguientes componentes:

- Cilindros de elevación
- Bomba
- Panel de control
- Tanque de depósito de aceite
- Estructura de soporte

Uso previsto

Esta máquina sólo se debe utilizar para elevar parcialmente vehículos en fosas ó en plataformas elevadoras (Fig.3).

Propósito del manual

Esta guía contiene o explica los siguientes tópicos:

- Instrucciones de seguridad y advertencias
- Especificaciones de la máquina
- Montaje
- Funcionamiento
- Mantenimiento
- Inspección de seguridad
- Planos de detalle y lista de repuestos
- Diagrama hidráulico
- Accesorios
- EU declaración de conformidad sobre maquinaria

DEFINICIÓN DE LOS SÍMBOLOS

- a** ADVERTENCIA: Tenga cuidado y utilice el producto correctamente. Este producto puede ocasionar lesiones graves o mortales tanto al operador como a cualquier otra persona.
- b** Lea detenidamente el manual de usuario y asegúrese de que entienda las instrucciones antes de usar la máquina (Fig.1).
- c** Cambie las piezas dañadas, desgastadas o rotas.
- d** Respete los requisitos de reciclaje locales y las normas aplicables.
- e** Montaje
- f** Funcionamiento
- g** Mantenimiento
- h** Solución de problemas
- i** Peligro de aplastamiento
- j** Transporte
- k** Mantenimiento diario
- l** Mantenimiento mensual
- m** Inspección de seguridad

RU *Перевод оригинального текста*

Описание изделия

Эта машина была построена из следующих компонентов:

- подъемные цилиндры
- насос
- панель управления
- резервуар
- несущая конструкция

Предназначение

Эту машину можно использовать только для частичного подъема транспортных средств в яме или на платформе (Fig. 3).

Цель руководства

Это руководство содержит или объясняет следующие темы:

- Предупреждения и инструкции по безопасному применению
- Технические характеристики машины
- Сборка
- Эксплуатация
- Техническое обслуживание
- Проверка обеспечения безопасности
- Диагностика неисправностей
- Детальные чертежи и запчасти
- Гидравлическая схема
- Аксессуары

УСЛОВНЫЕ ОБОЗНАЧЕНИЯ НА ИЗДЕЛИИ

- a** ПРЕДУПРЕЖДЕНИЕ! Соблюдайте осторожность и правила эксплуатации изделия. Изделие может стать причиной тяжелой травмы или смерти оператора и окружающих.
- b** Перед началом работы внимательно прочитайте руководство по эксплуатации и убедитесь, что понимаете приведенные здесь инструкции (Fig. 1).
- c** Замените поврежденные, сломанные или изношенные детали.
- d** Соблюдайте местное законодательство и действующие нормы в области переработки.
- e** Сборка
- f** Эксплуатация
- g** Техническое обслуживание
- h** Диагностика неисправностей
- i** Опасность раздавить
- j** Транспорт
- k** Ежедневное обслуживание
- l** Ежемесячное обслуживание
- m** Проверка обеспечения безопасности

IT *Traduzione del testo originale*

Descrizione del prodotto

Questa macchina è stata costruita con i seguenti componenti:

- Cilindri di sollevamento
- Pompa
- Pannello di controllo
- Serbatoio
- Struttura di supporto

Utilizzo previsto

Questa macchina deve essere utilizzata esclusivamente per il sollevamento parziale dei veicoli in una fossa o in una piattaforma (Fig. 3).

Scopo del manuale

Questa guida contiene o descrive i seguenti argomenti:

- Istruzioni per un uso sicuro e avvertenze
- Specifiche della macchina
- Montaggio
- Operazione
- Manutenzione
- Controllo di sicurezza
- Risoluzione dei problemi
- Disegni dettagliati e pezzi di ricambio
- Schema idraulico
- Accessori
- Dichiarazione di conformità UE

SIMBOLOGIA

- a** AVVERTENZA! Prestare attenzione e utilizzare il prodotto correttamente. Il prodotto può causare gravi lesioni o morte dell'operatore o altre persone.
- b** Prima dell'uso, leggere per intero il manuale dell'operatore e accertarsi di aver compreso le istruzioni (Fig. 1).
- c** Sostituire le parti danneggiate, usurate o rotte.
- d** Rispettare le norme locali sul riciclaggio e le normative vigenti.
- e** Montaggio
- f** Utilizzo
- g** Manutenzione
- h** Risoluzione dei problemi
- i** Pericolo di schiacciamento
- j** Transporti
- k** Manutenzione giornaliera
- l** Manutenzione mensile
- m** Controllo di sicurezza

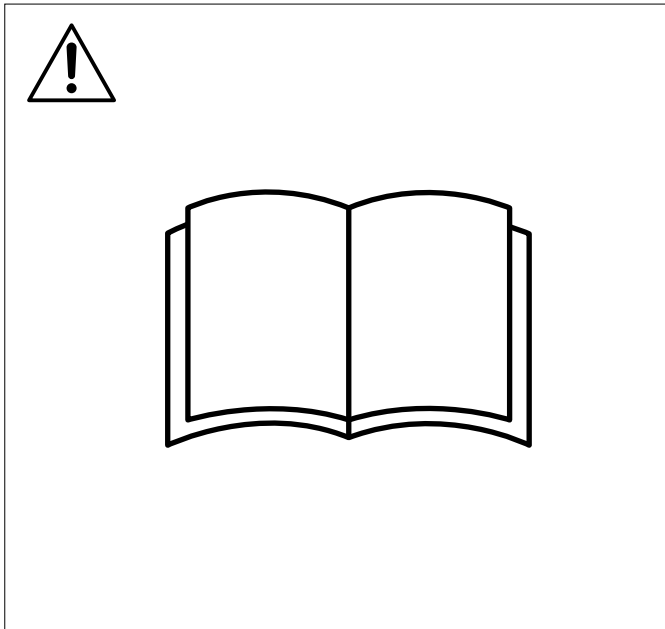

Fig.1

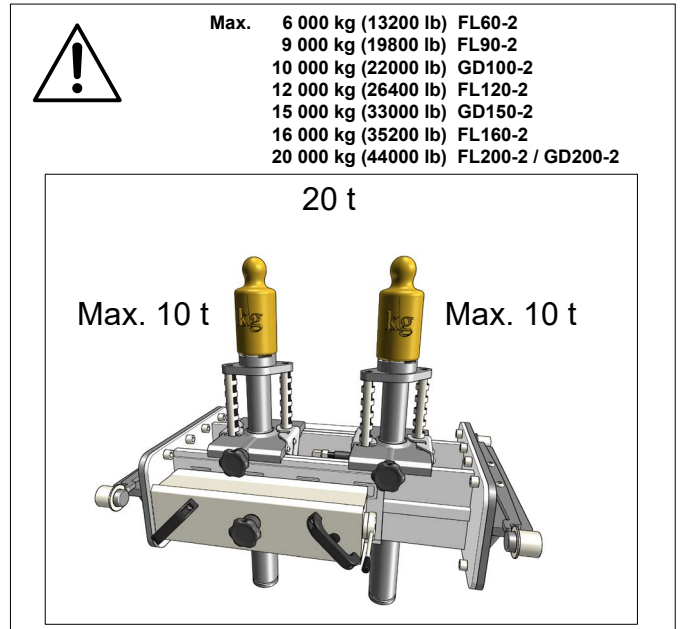

Fig.2

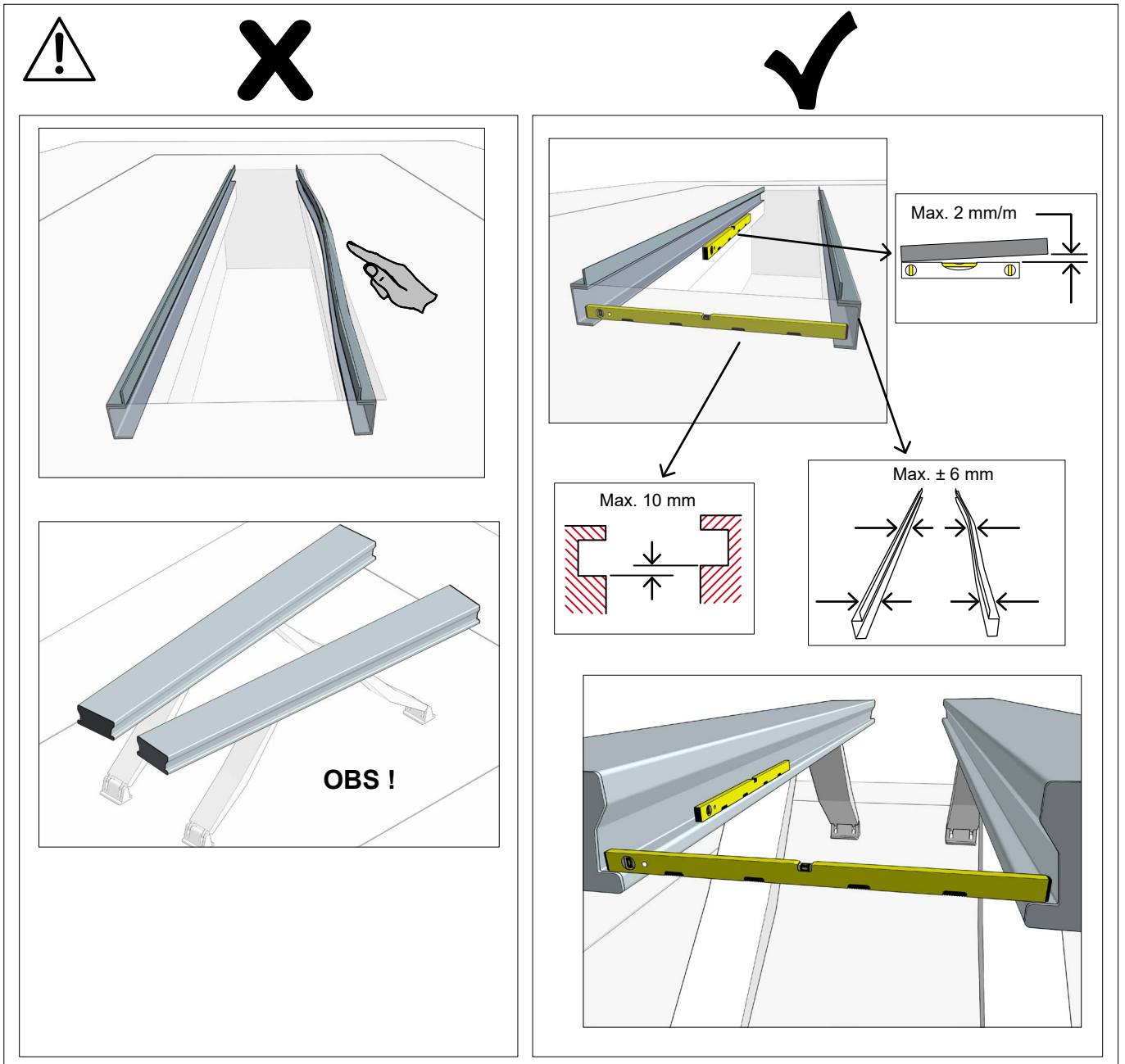

Fig.3

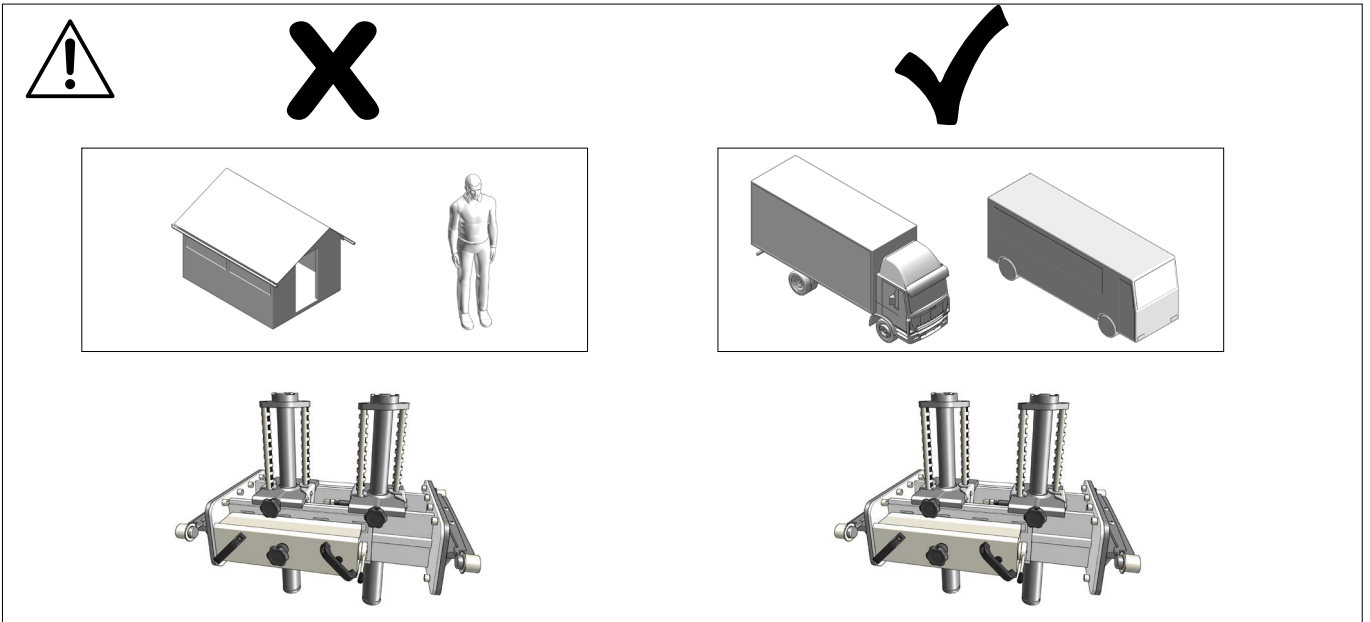

Fig. 4

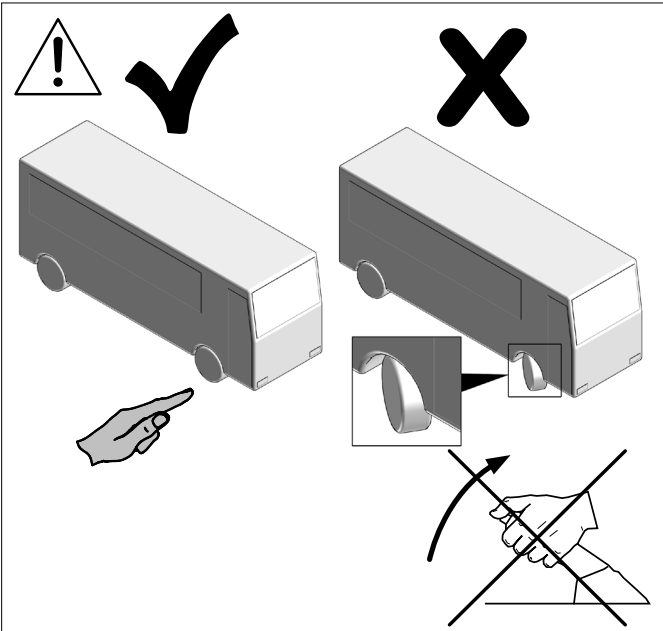

Fig. 5

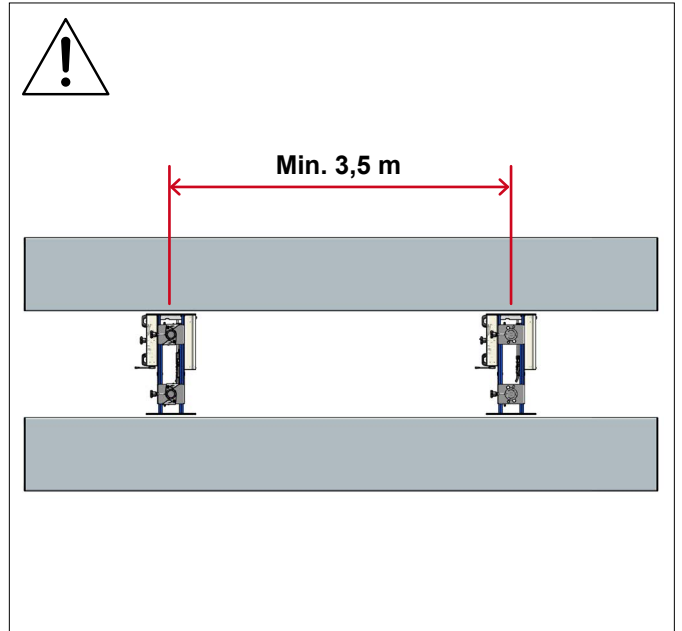

Fig. 6

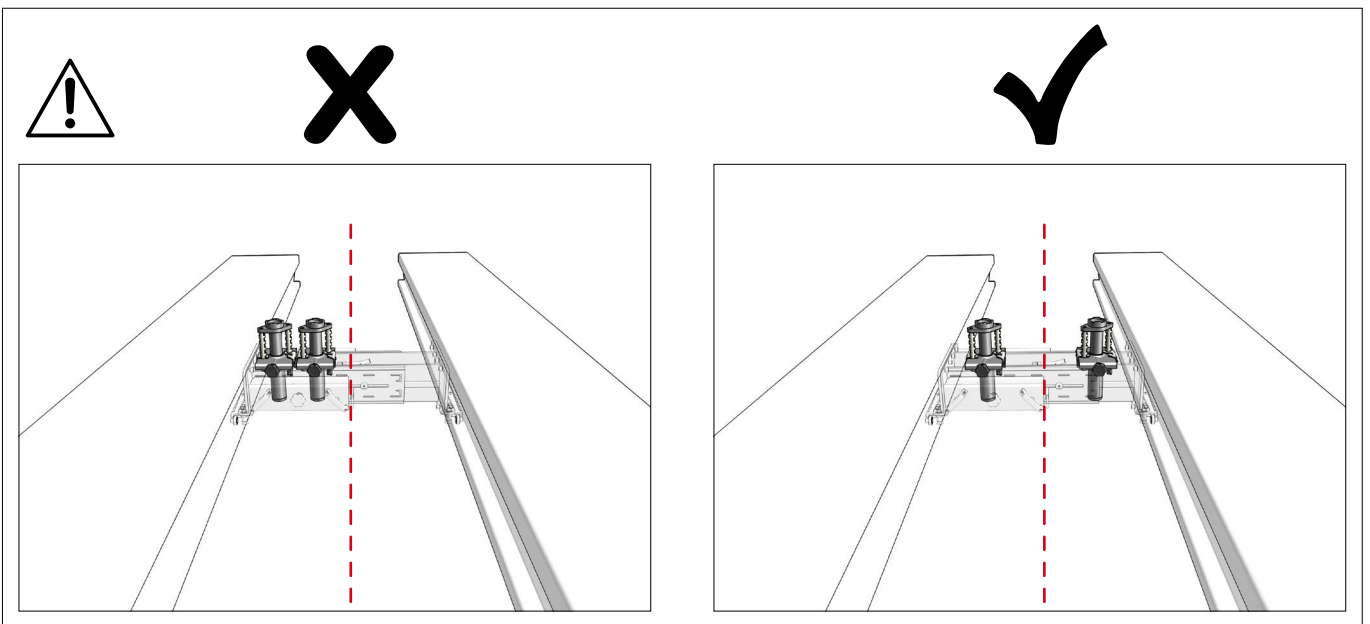

Fig. 7

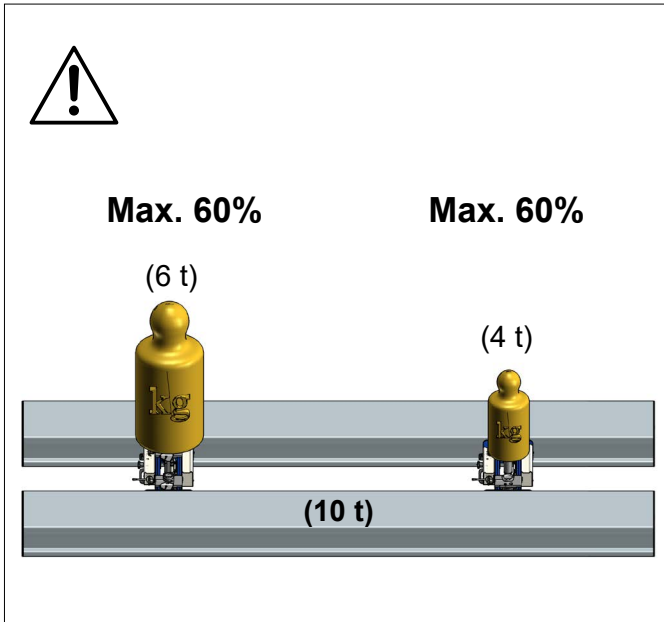

Fig.8

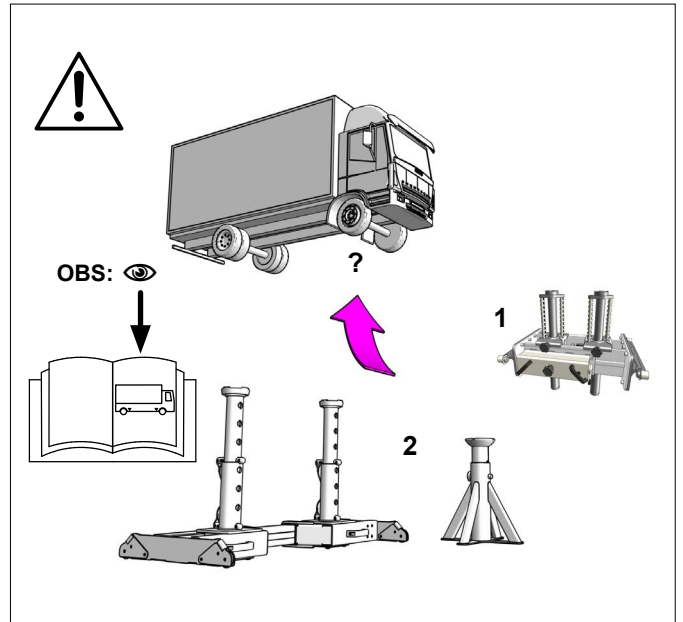

Fig.9

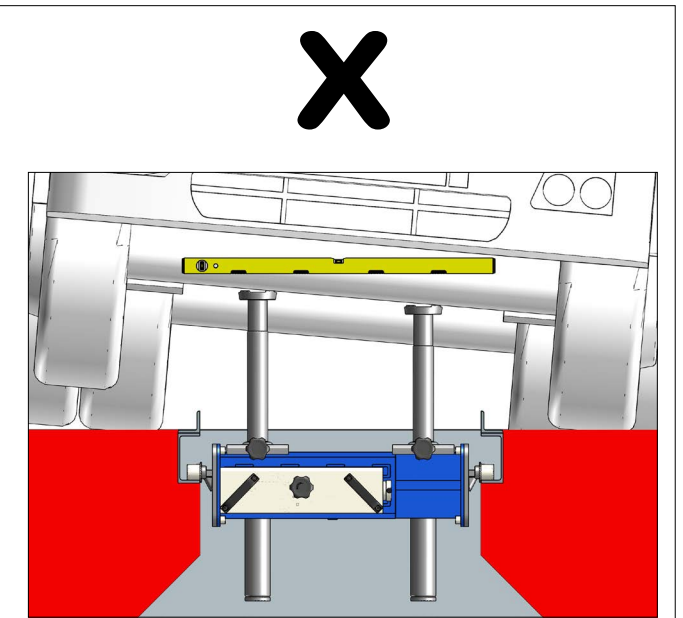
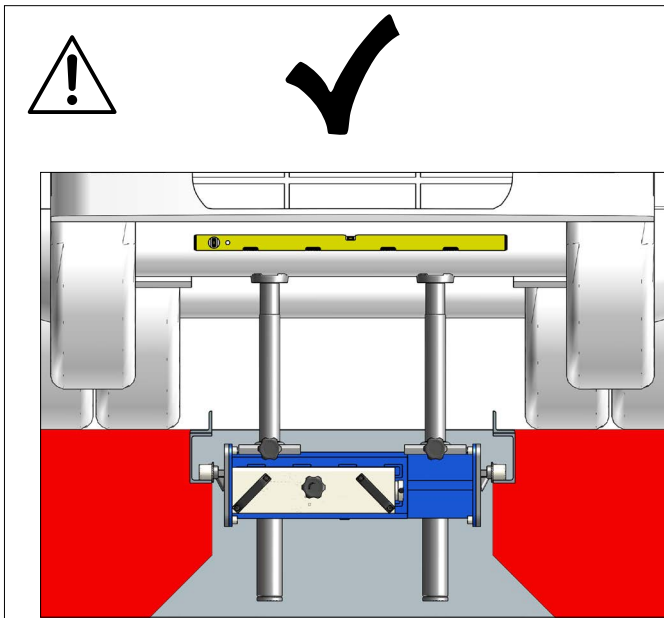

Fig.10

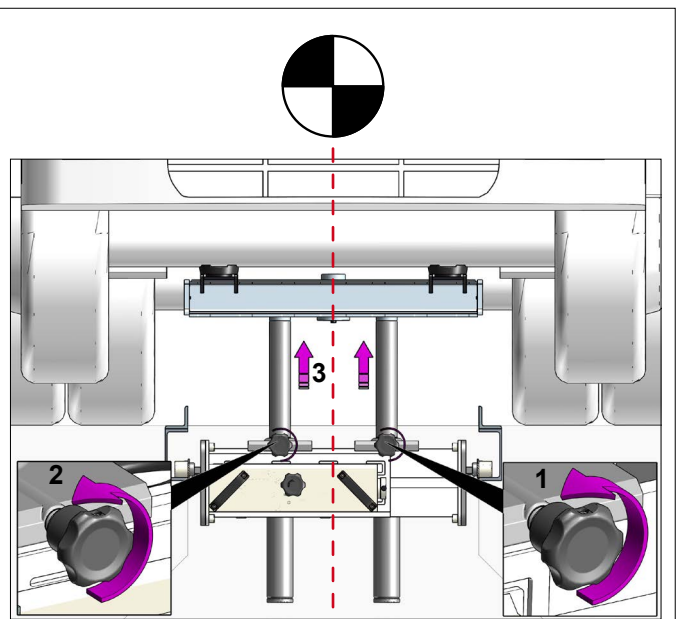
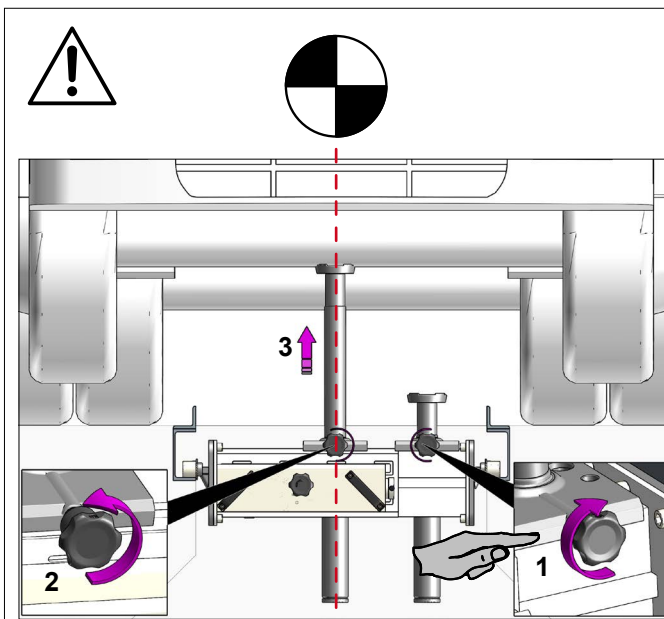

Fig.11

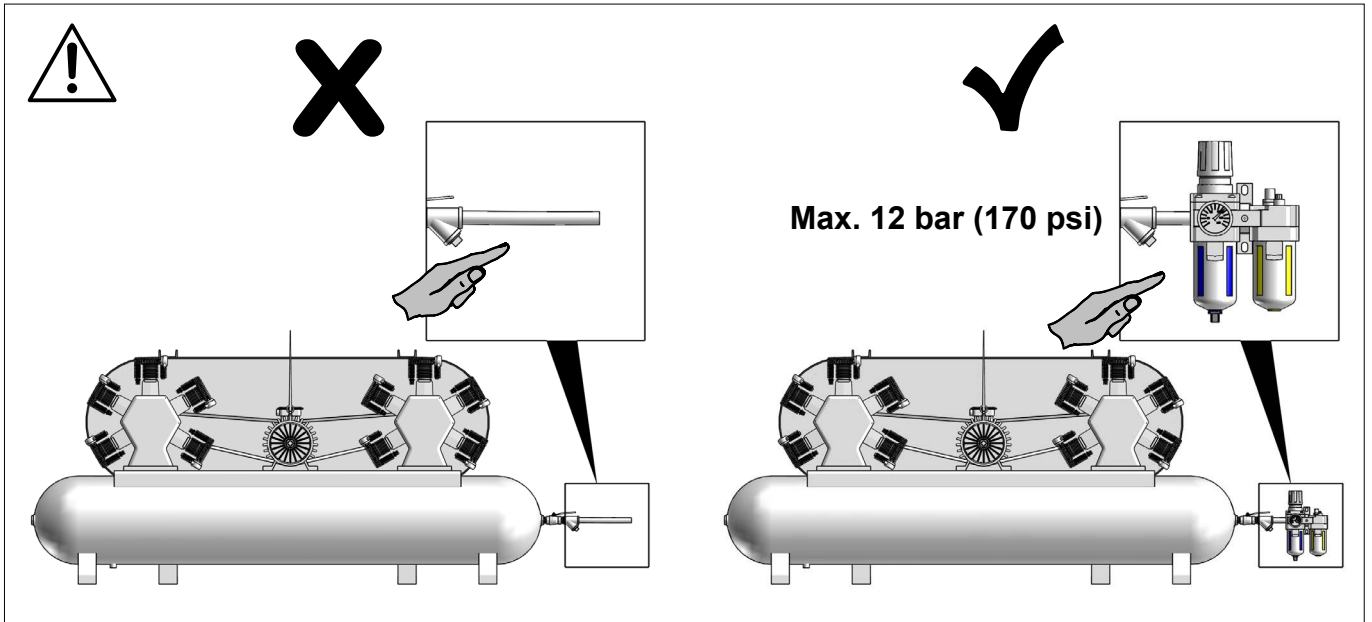

Fig.12

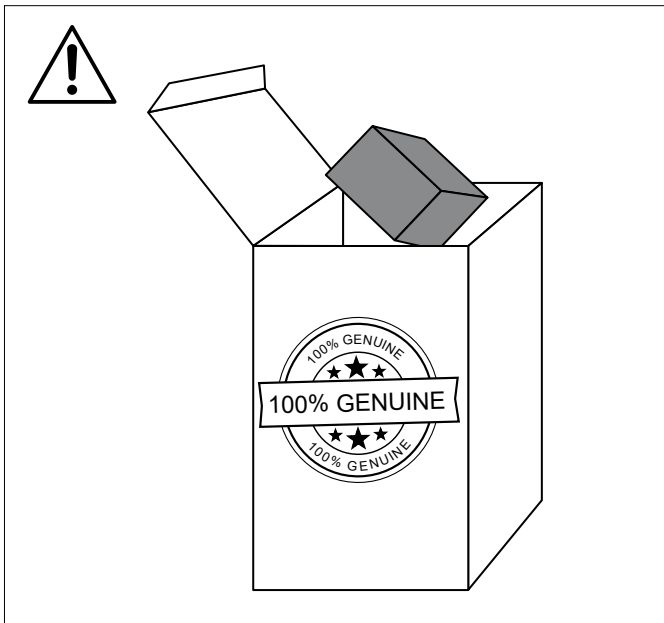

Fig.13

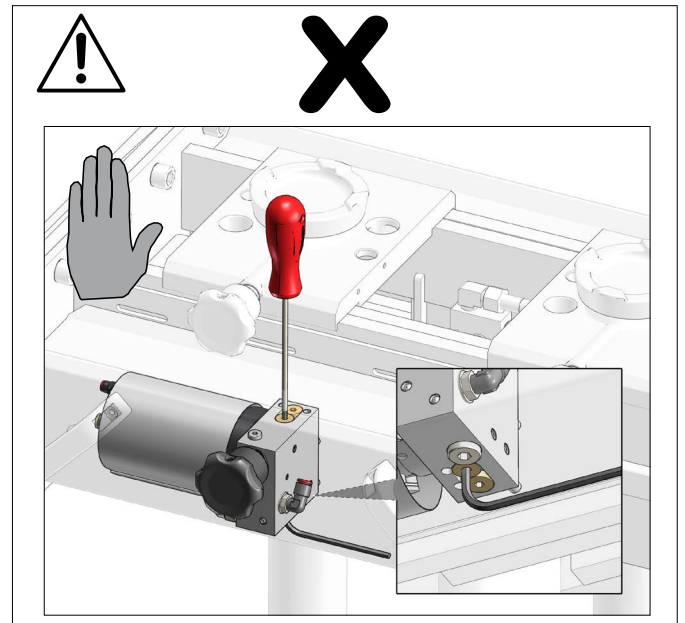

Fig.14

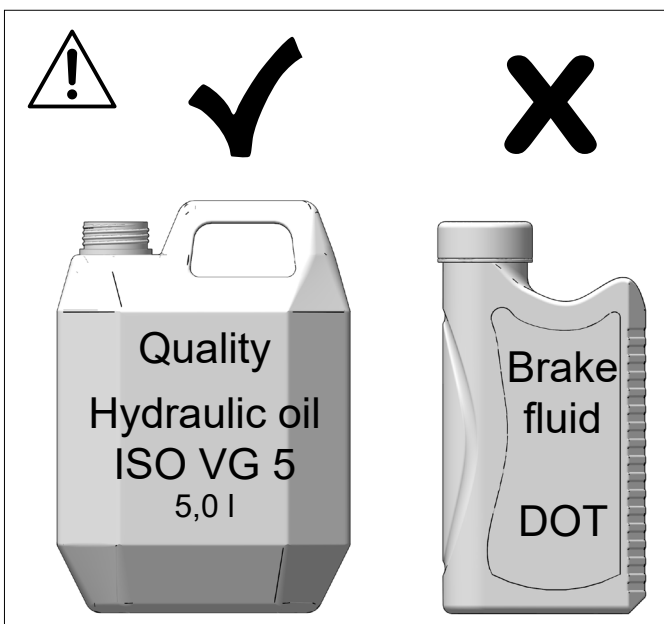

Fig.15

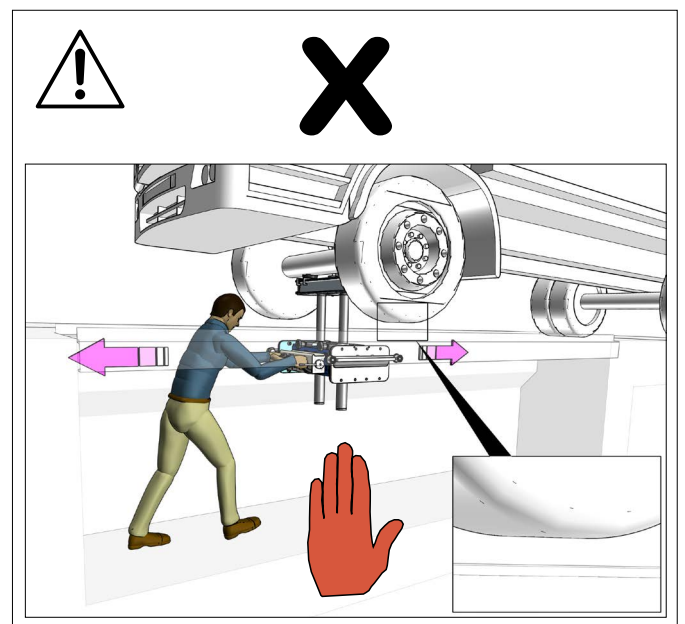

Fig.16

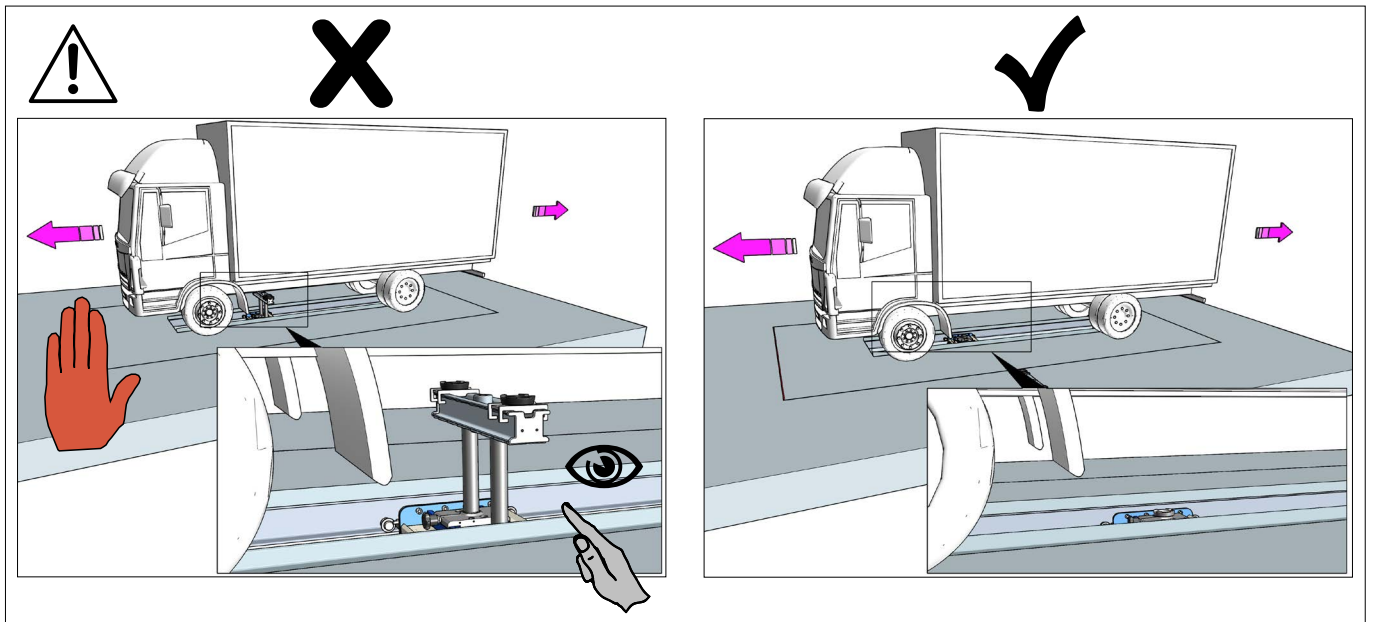

Fig.17

Specifications

GD

10, 15, 20 t

(Fig.18)

(Fig.19)

30 + (Fig.18) +
2(Fig.19) + (Fig.20)

8 - 12 bar
(116 - 170 psi)

8 bar (116 psi)

350 l/min

ISO VG 5

5,0 l

-20 / +50°C

≤ 80 dB(A)

FL

6, 9, 12, 16, 20 t

(Fig.18)

(Fig.19)

30 + (Fig.18) +
2(Fig.19) + (Fig.20)

8 - 12 bar
(116 - 170 psi)

8 bar (116 psi)

350 l/min

ISO VG 5

5,0 l

-20 / +50°C

≤ 80 dB(A)

Specifikationer

Fuld kapacitet

Bredde

Slaglængde

Vægt, kg

Forsyningstryk

Fuld kapacitet opnås fra

Luftforbrug

Hydraulik olie

Oliemængde

Temperaturområde

Lydtryksniveau

Specifications

Capacity

Width

Stroke

Weight, kg

Air supply

Top capacity reaches at

Air consumption

Hydraulic oil

Oil quantity

Temperature range

Sound pressure level

Spezifikationen

Kapazität

Breite

Kolbenhub

Gewicht, kg

Betriebsdruck

Volle Kapazität ab

Luftverbrauch

Hydrauliköl

Ölmenge

Temperaturbereich

Schalldruckpegel

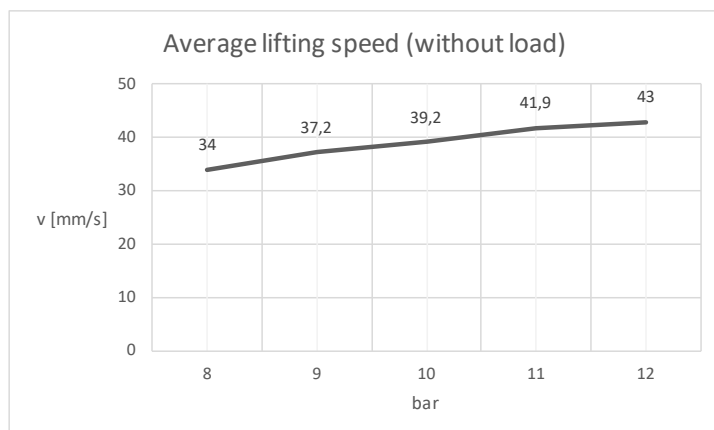

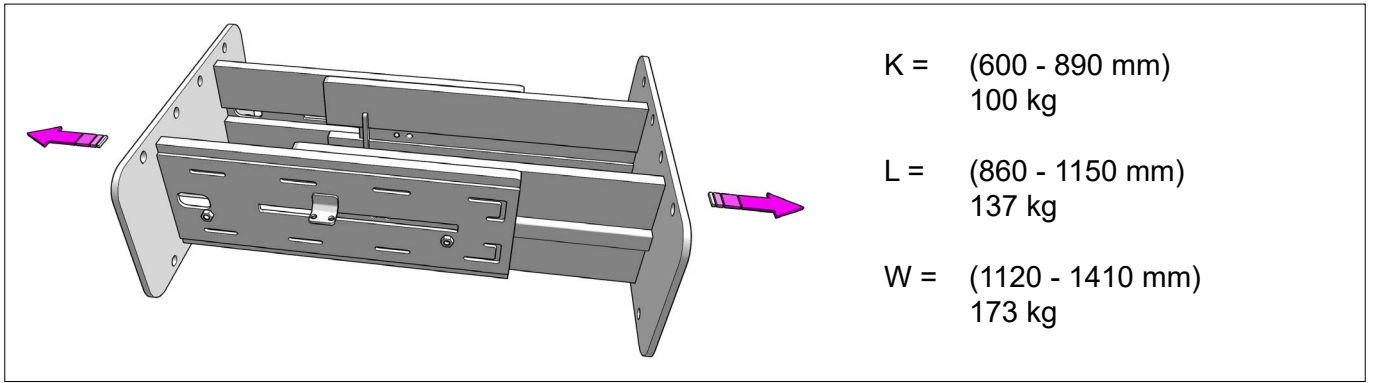

Fig.18

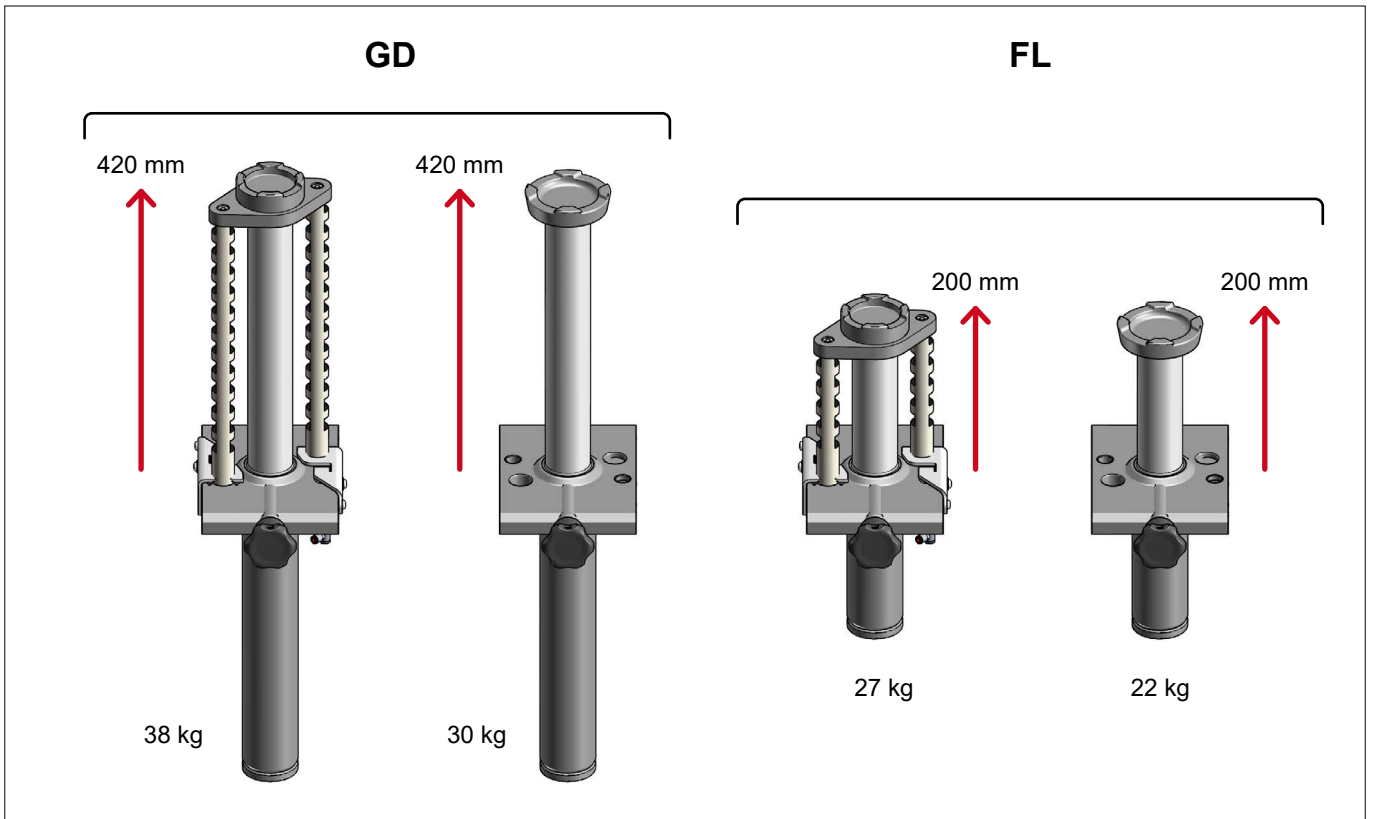

Fig.19

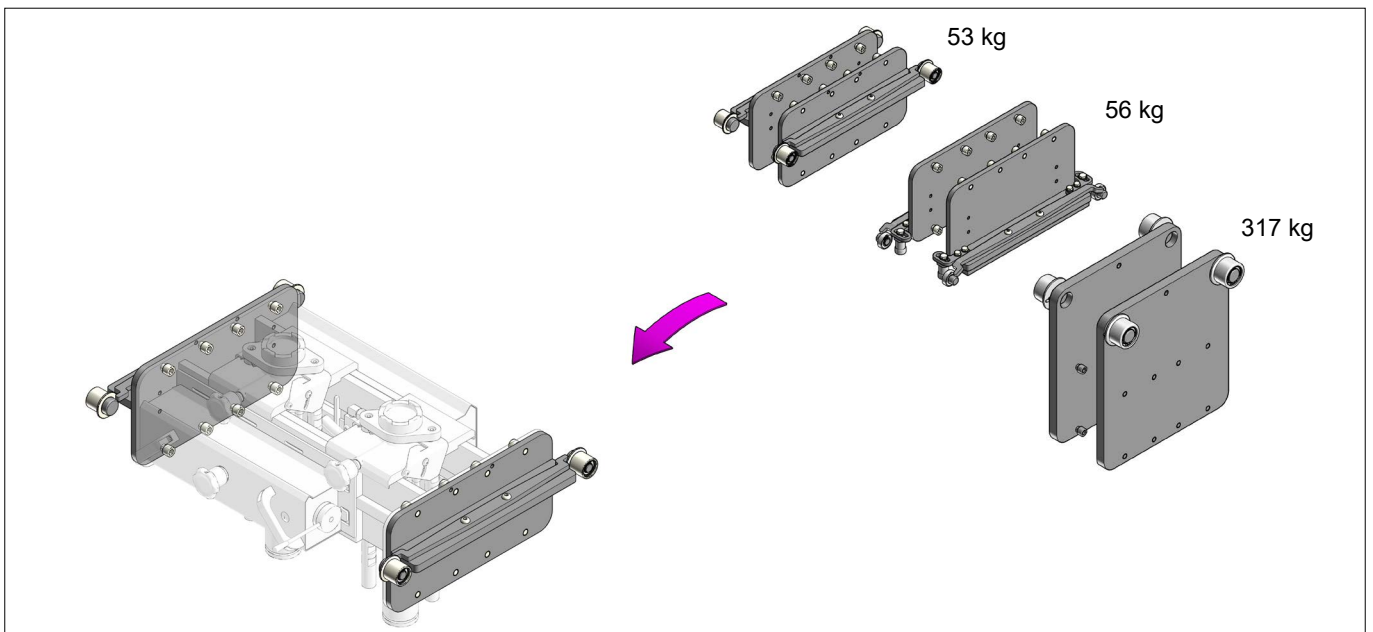
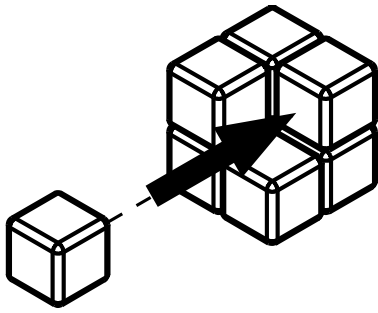

Fig.20



ⓀⓃ NO Montering

ⒼⒷ Assembly

ⒹⒺ Montage

ⒻⓇ Assemblage

ⓈⒺ Montering

ⒻⒾ Asentaminen

ⓃⒻ Assemblage

ⒺⓈ Montaje

ⓇⓊ Сборка

ⒾⓉ Montaggio

GD

FL

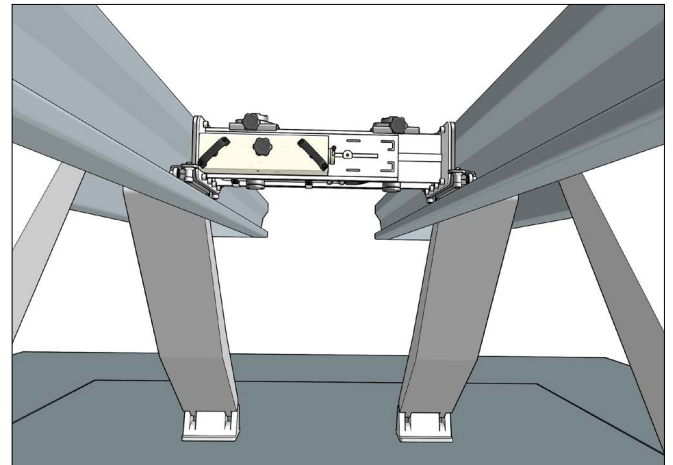
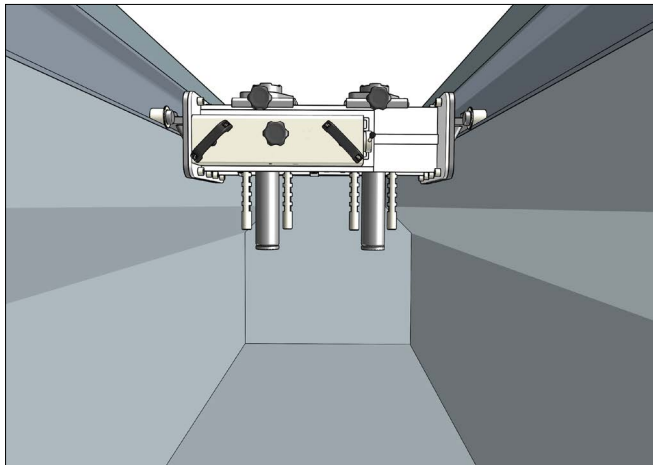

Fig.21

1

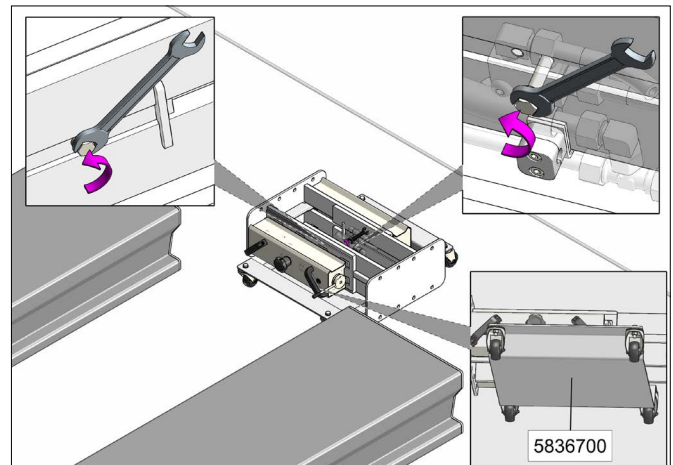
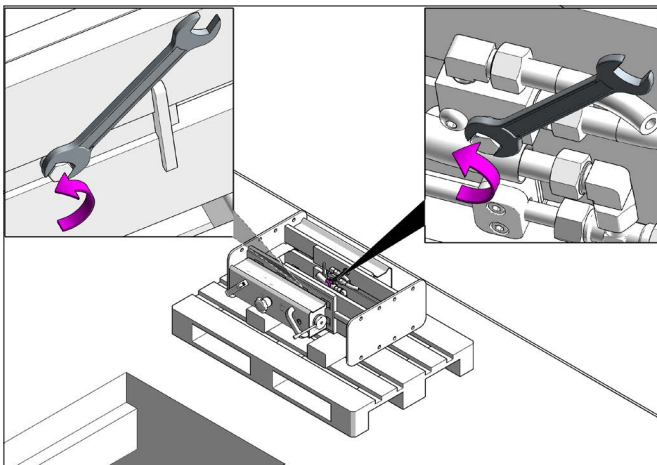
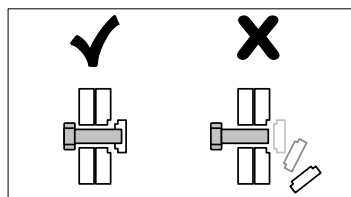

Fig.22

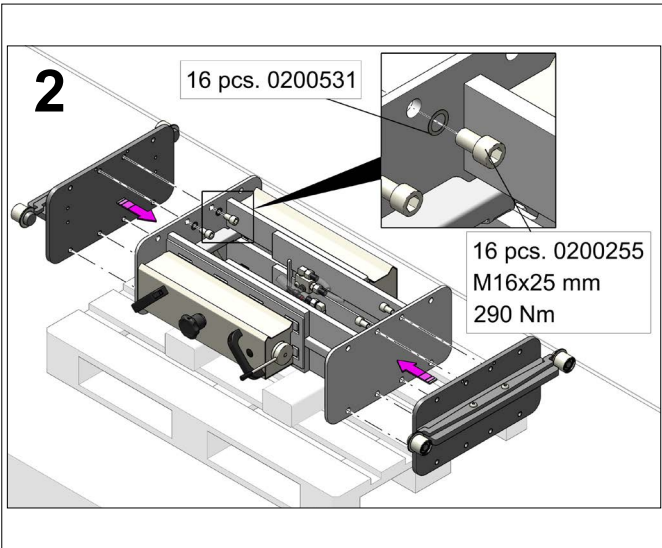

Fig.23

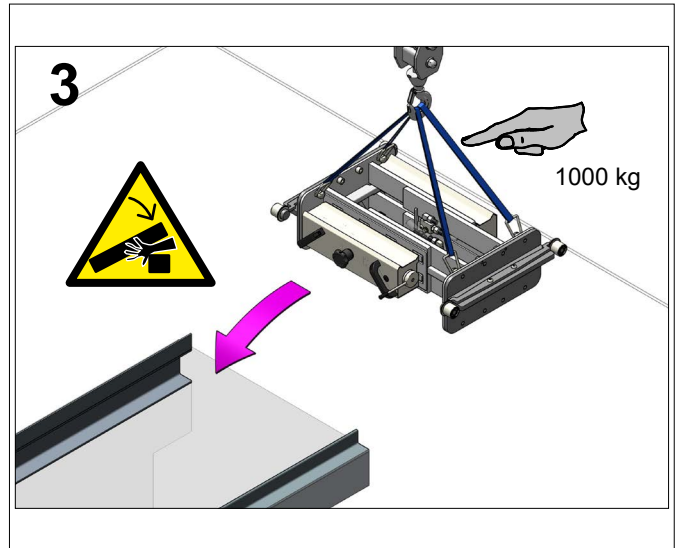

Fig.24

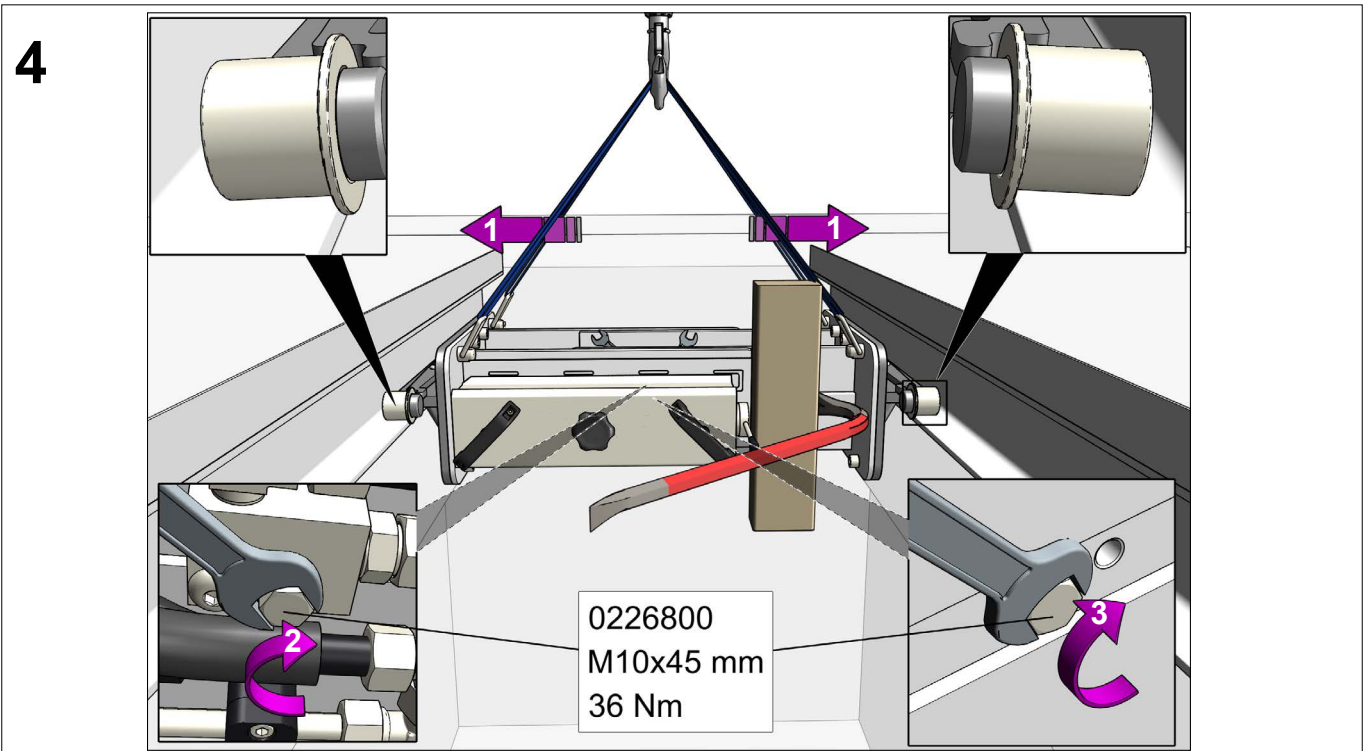

Fig.25

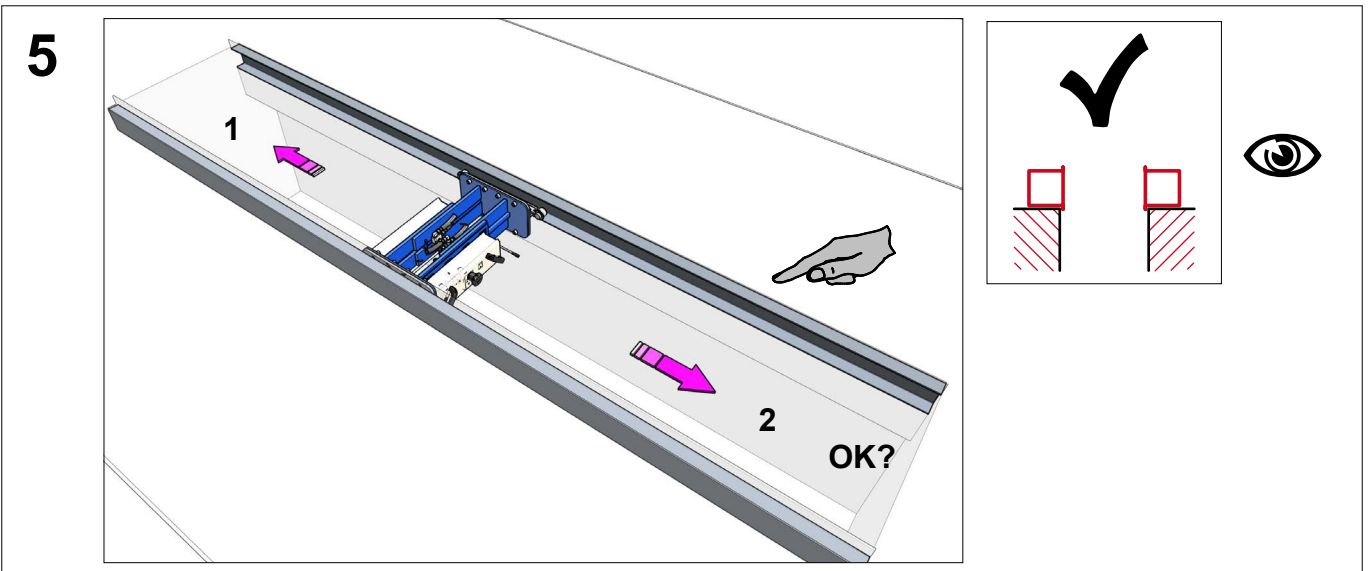

Fig.26

6

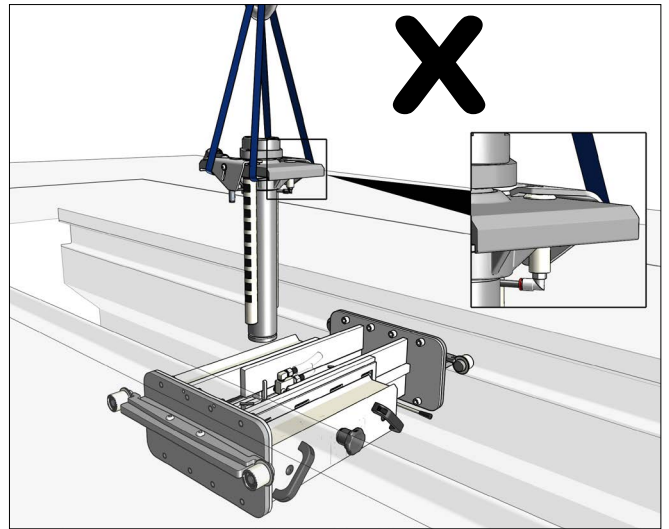
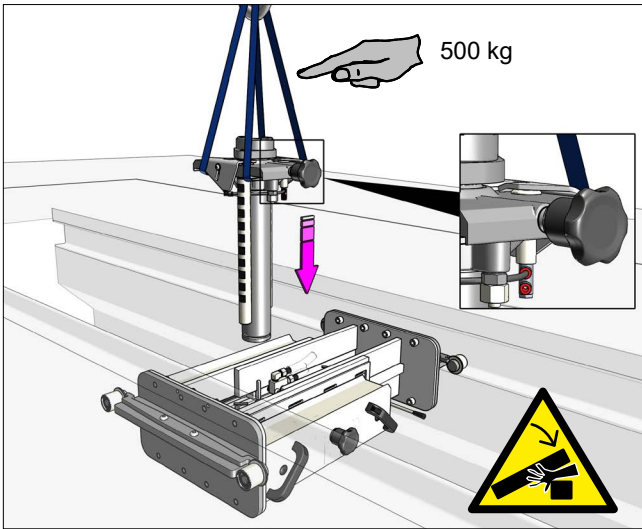

Fig.27

7

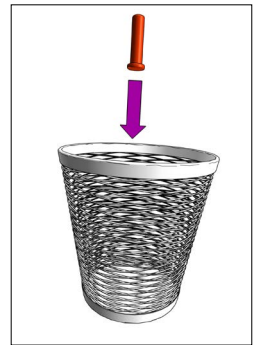
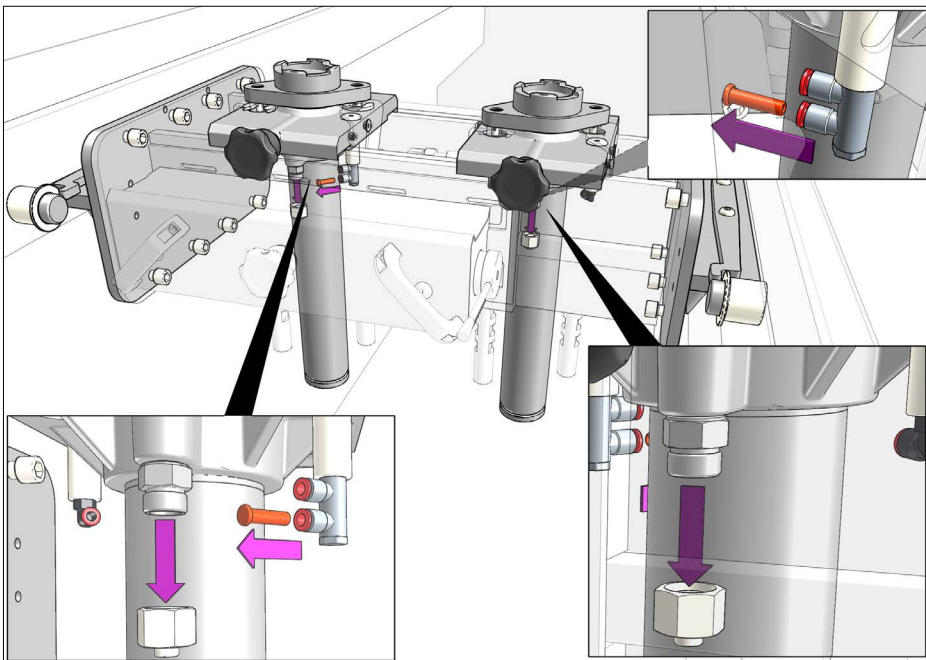

Fig.28

8

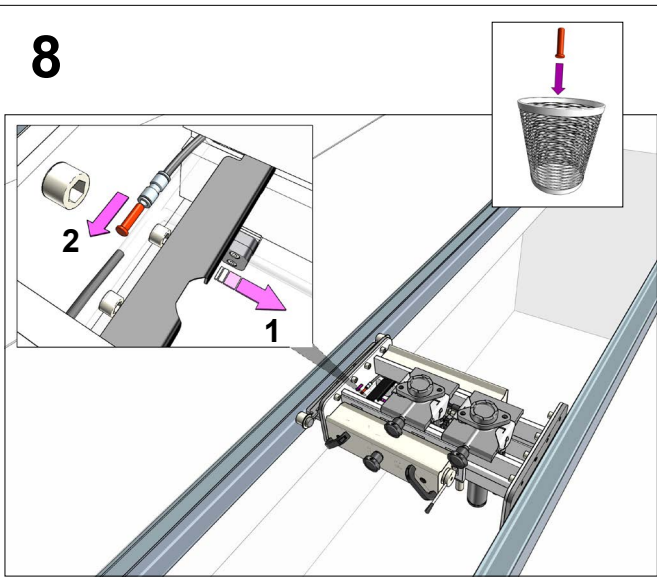

Fig.29

9

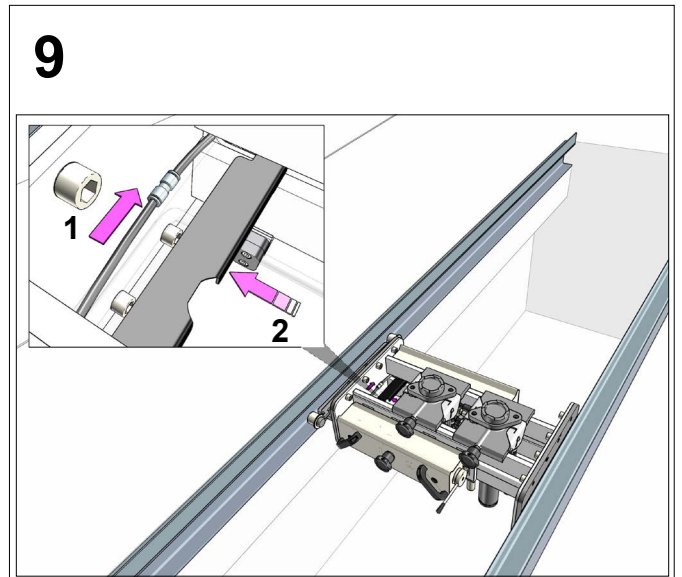

Fig.30

10

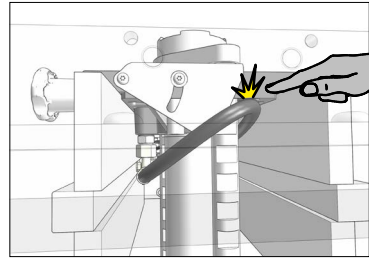
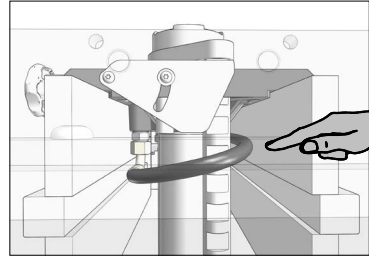
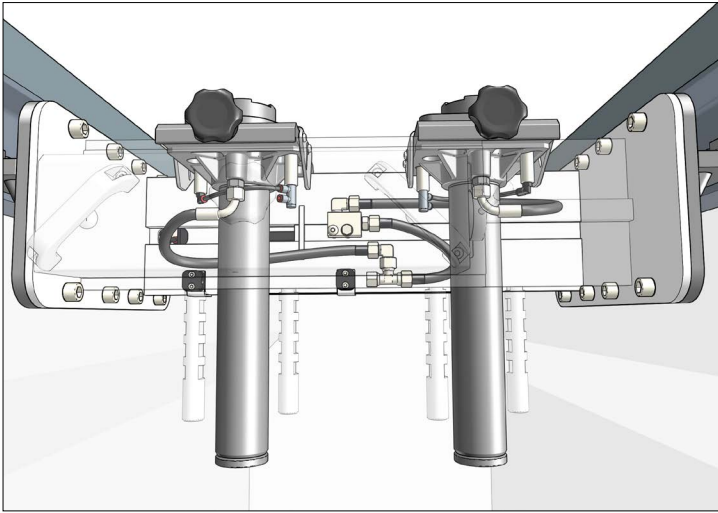

Fig.31

11

FL-2M
GD-2M

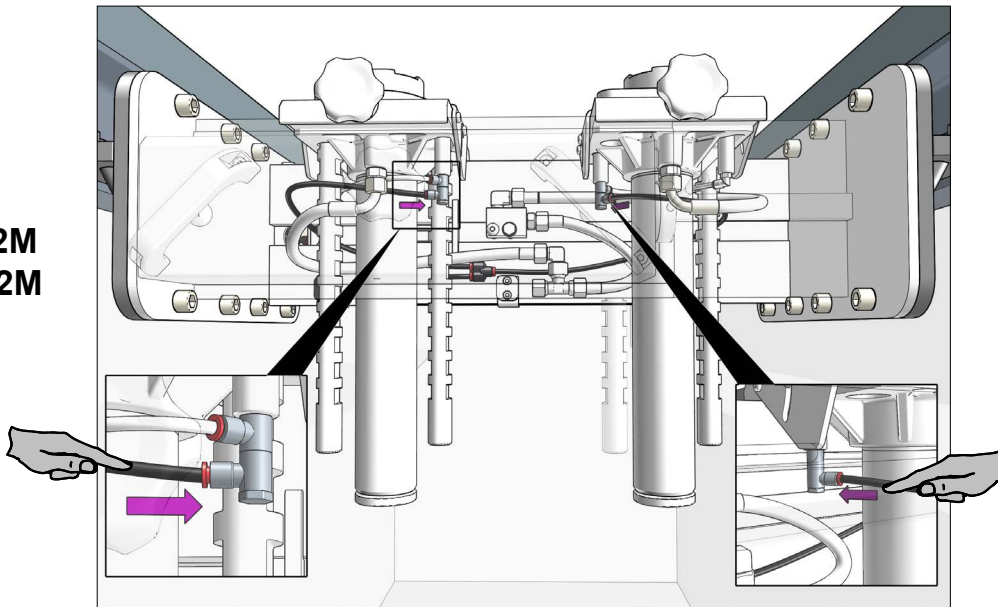

Fig.32

12

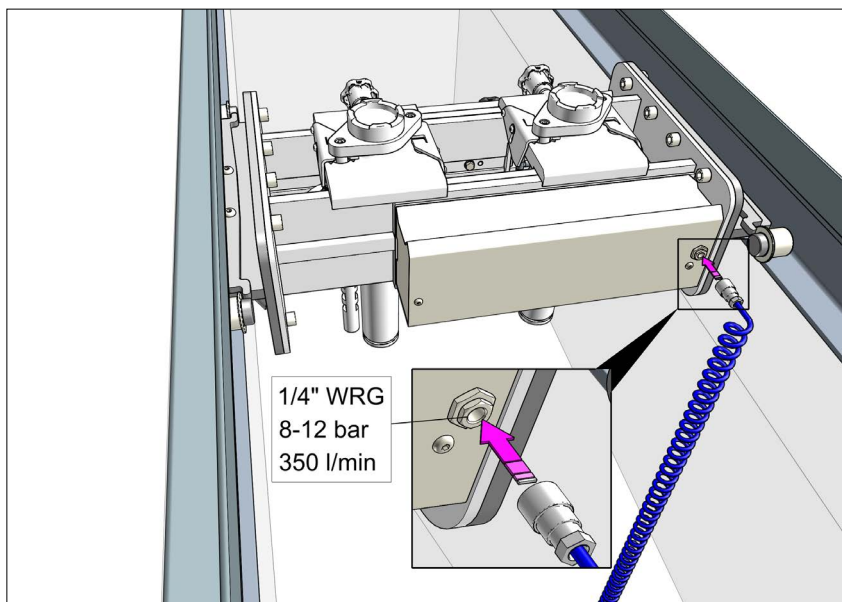



Fig.33

13

2 x 

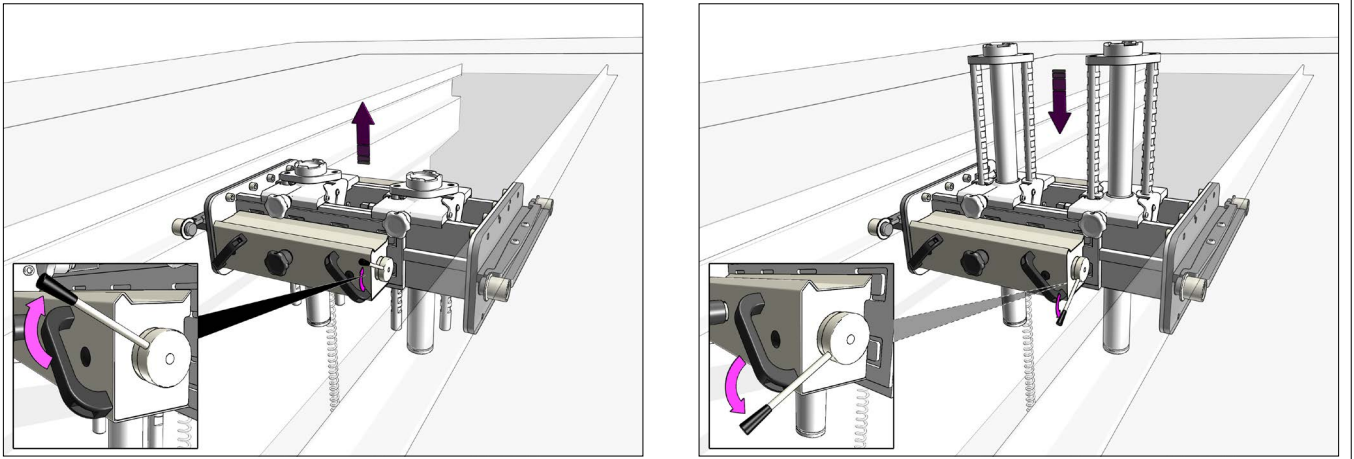
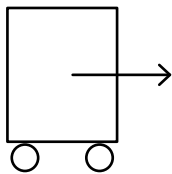

Fig.34



- Ⓚ (DK) (NO) Transport
- Ⓚ (GB) Transportation
- Ⓚ (DE) Transport
- Ⓚ (FR) Transport
- Ⓚ (SE) Transport
- Ⓚ (FI) Kuljetus
- Ⓚ (NL) Vervoer
- Ⓚ (ES) Transporte
- Ⓚ (RU) Транспорт
- Ⓚ (IT) Transporti

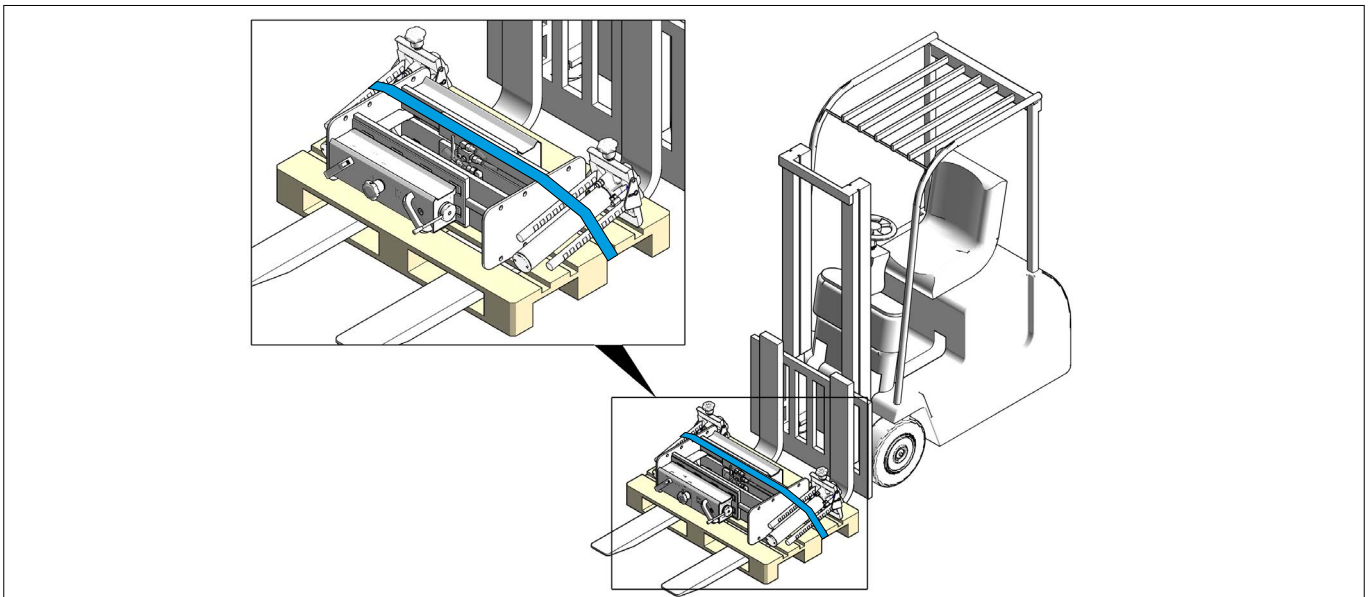
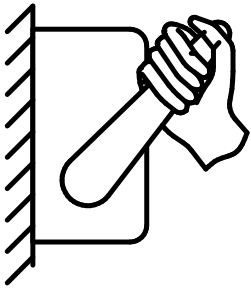

Fig.35



(DK) Betjening - Løft kun på løftepunkter, som foreskrevet af bil-fabrikanten. Vær sikker på, at køretøjet ikke kan skride (Fig.9), (Fig.10), (Fig.11).

(NO) Operation - Lift exactly on the lifting point specified by the vehicle manufacturer. Make sure that the vehicle cannot slide (Fig.9), (Fig.10), (Fig.11).

(DE) Bedienung - Das Fahrzeug nur auf den vom Hersteller des Fahr. zeugs angewiesenen Hebe punkten stützen lassen. Stellen Sie sicher, dass das Fahrzeug nicht abrutschen kann (Fig.9), (Fig.10), (Fig.11).

(FR) Utilisation - Ne lever qu'aux points spécifiés par le constructeur automobile. Contrôler que le véhicule ne peut pas glisser (Fig.9), (Fig.10), (Fig.11).

(SE) Drift - Lyft endast på de lyftpunkter som bitillverkaren rekommenderar. Säkerställ att fordonet inte kan börja glida (Fig.9), (Fig.10), (Fig.11).

(FI) Käyttö - Nosta vain ajoneuvon valmistajan määrittämistä kohdista. Varmista, ettei ajoneuvo pääse liukumaan (Fig.9), (Fig.10), (Fig.11).

(NL) Werking - De last enkel opheffen op de draagpunten, voorgeschreven door de fabrikant. Zorg ervoor dat het voertuig niet kan wegschuiven (Fig.9), (Fig.10), (Fig.11).

(ES) Funcionamiento - Eleve el vehículo únicamente en los puntos especificados por el fabricante del automóvil. Asegúrese de que el vehículo no se deslice (Fig.9), (Fig.10), (Fig.11).

(RU) Эксплуатация - Подъем транспортного средства разрешается производить только с упором на точки подъема, указанные его производителем. Убедитесь в том, что транспортное средство не может соскользнуть (Fig.9), (Fig.10), (Fig.11).

(IT) Utilizzo - Utilizzare esclusivamente i punti di sollevamento previsti dal produttore del veicolo. Assicurarsi che il veicolo non possa scorrere (Fig.9), (Fig.10), (Fig.11).

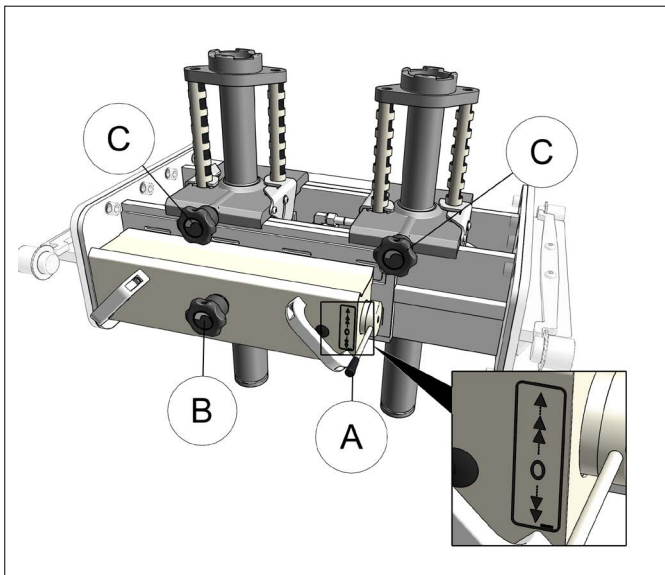

Fig.36

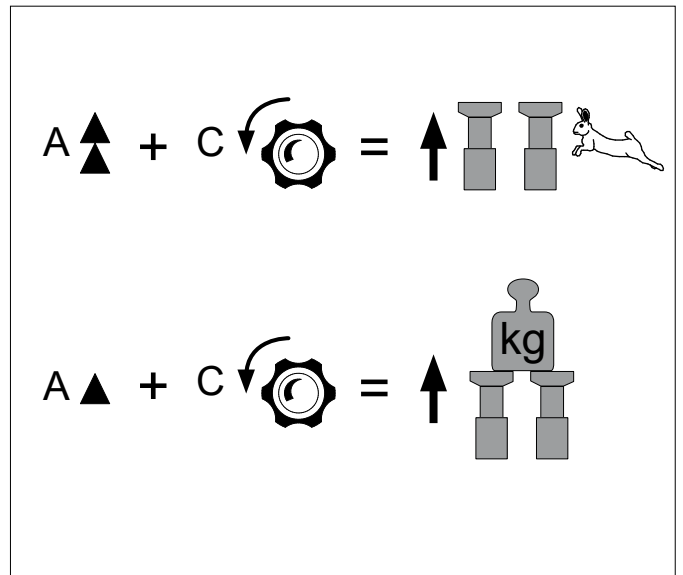

Fig.37

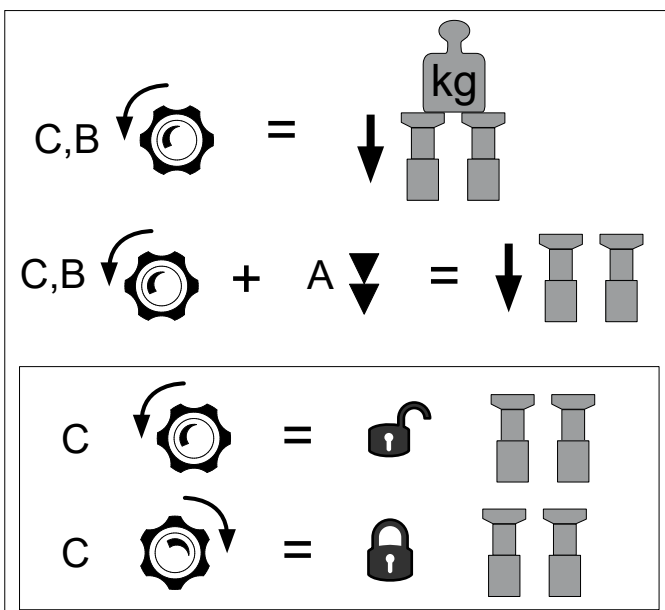

Fig.38

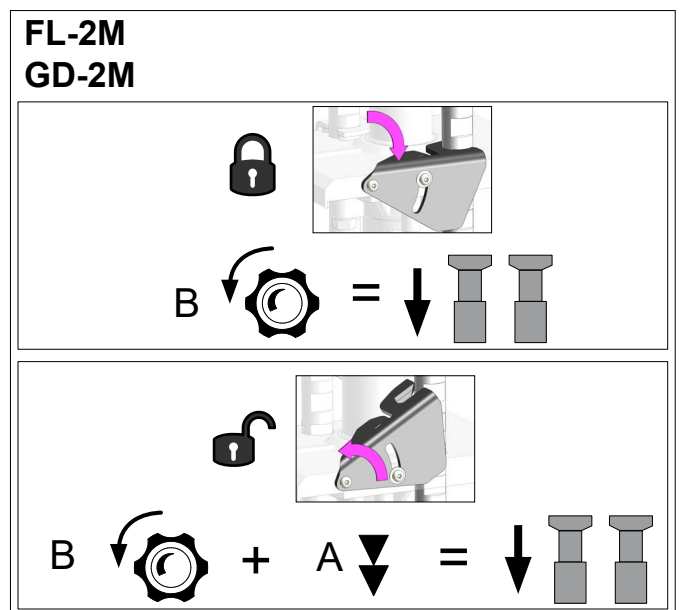
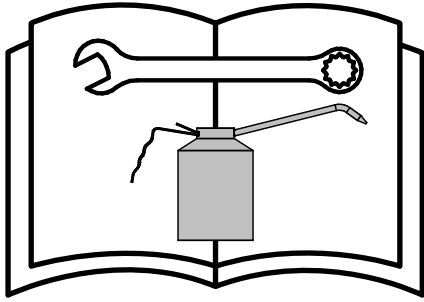

Fig.39



- Ⓚ **Vedligeholdelse** - Vedligehold og reparation må kun foretages af kvalificeret personale.
- Ⓒ **Users Maintenance** - Maintenance and repair must always be carried out by qualified personnel.
- Ⓓ **Wartung** - Wartungs- und Reparaturarbeiten dürfen nur von qualifiziertem Personal durchgeführt werden.
- Ⓕ **Maintenance** - La maintenance et les réparations doivent toujours être effectuées par un personnel qualifié.

- Ⓢ **Underhåll** - Underhåll och reparationer måste alltid utföras av utbildad personal.
- Ⓕ **Kunnossapito** - Kunnossapitotehtävissä ja korjauksissa tarvitaan aina ammattitaitoista henkilöä.
- Ⓖ **Onderhoud** - Onderhoudswerkzaamheden en herstellingen moeten steeds door bevoegd personeel worden uitgevoerd.
- Ⓢ **Mantenimiento** - El mantenimiento y las reparaciones deben ser ejecutados por personal calificado.
- Ⓔ **Техническое обслуживание** - Техническое обслуживание и ремонт должны выполняться только квалифицированным персоналом.
- Ⓘ **Manutenzione** - Manutenzione e riparazione devono essere sempre effettuate da personale qualificato.

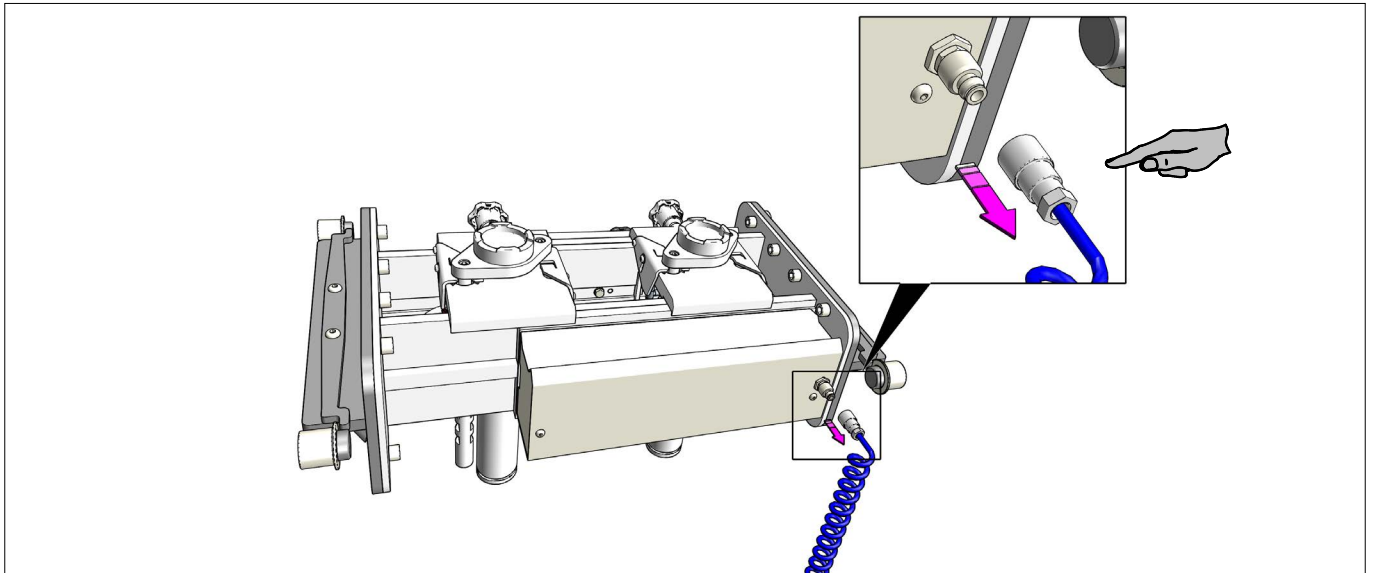

Fig.40

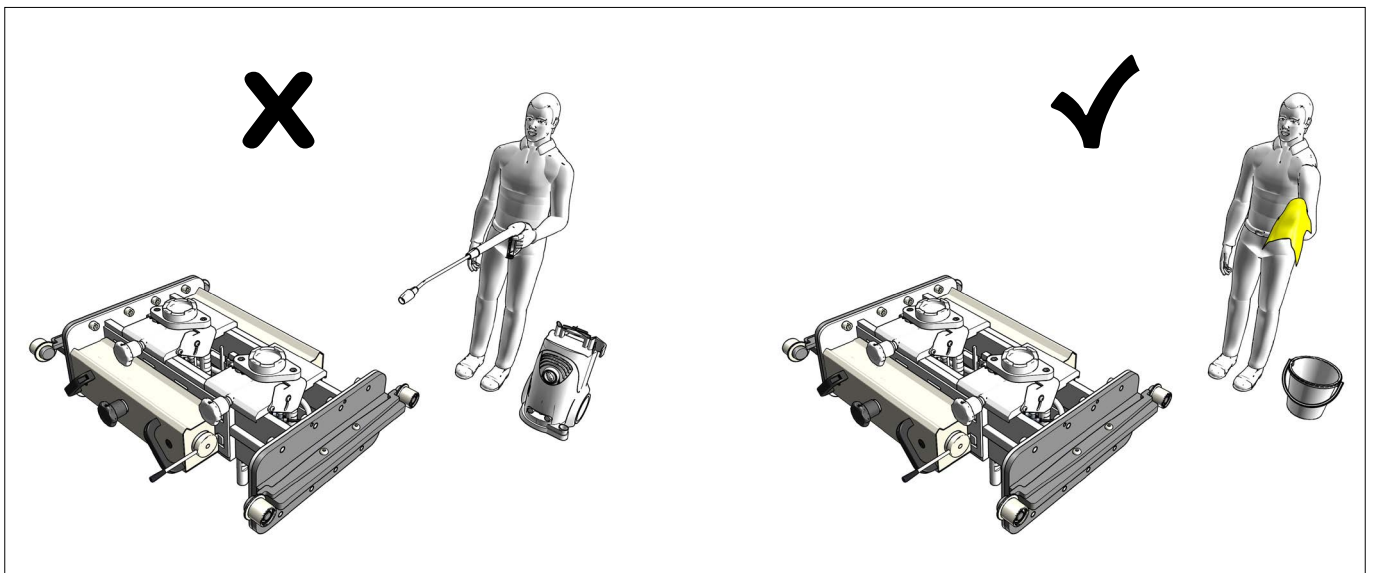

Fig.41

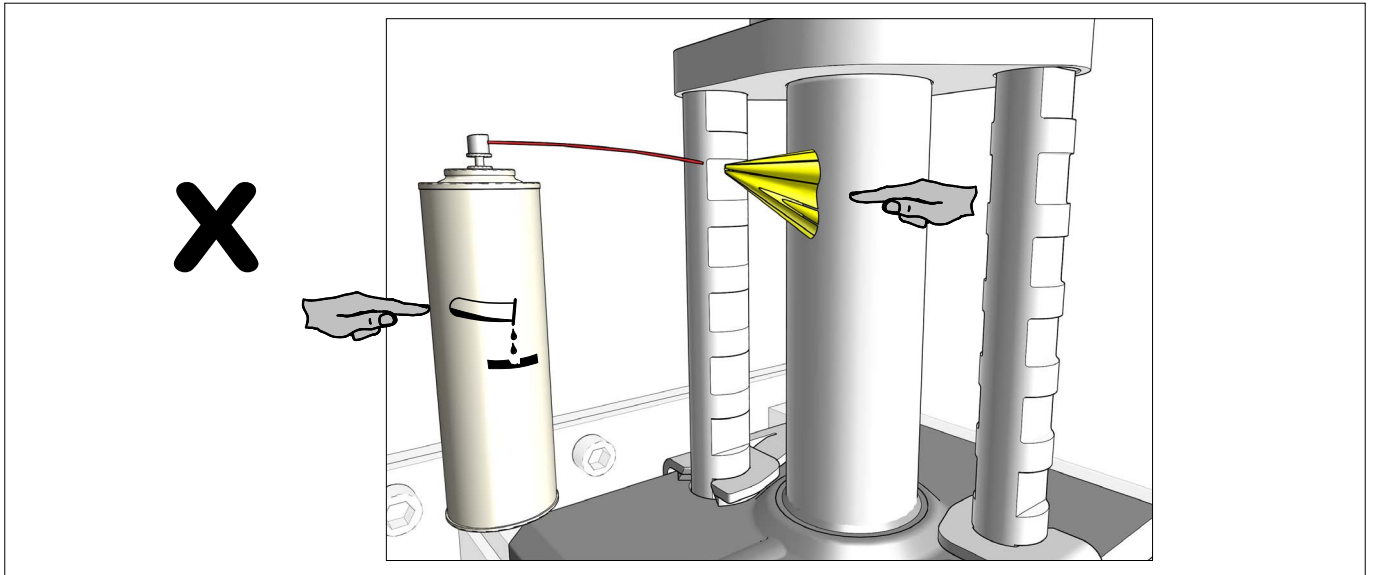
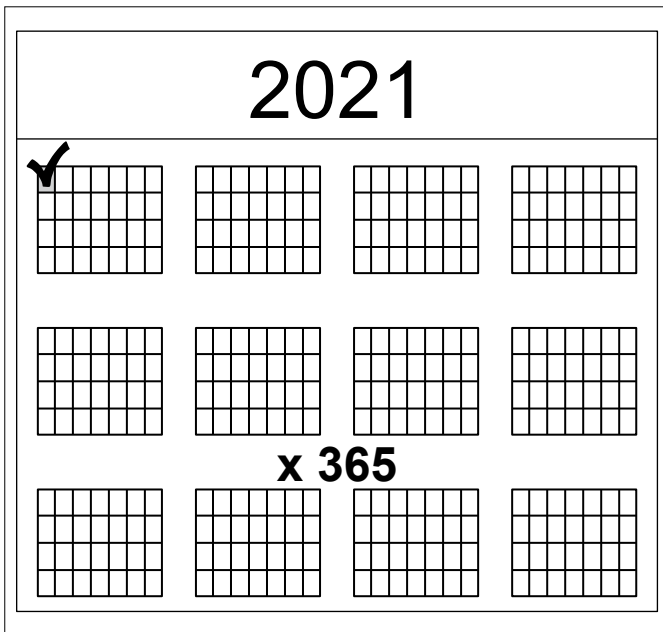

Fig.42



- ⓀⓃ (DK) Dagligt
- ⓀⓅ (GB) Daily
- Ⓚⓔ (DE) Tägliche Inspektion
- ⓀⓇ (FR) Tous les jours
- Ⓚⓔ (SE) Dagligen
- ⓀⓇ (FI) Päivittäin
- ⓀⓃ (NL) Dagelijks
- Ⓚⓔ (ES) Diariamente
- ⓀⓇ (RU) Ежедневно
- ⓀⓇ (IT) Operazioni quotidiane

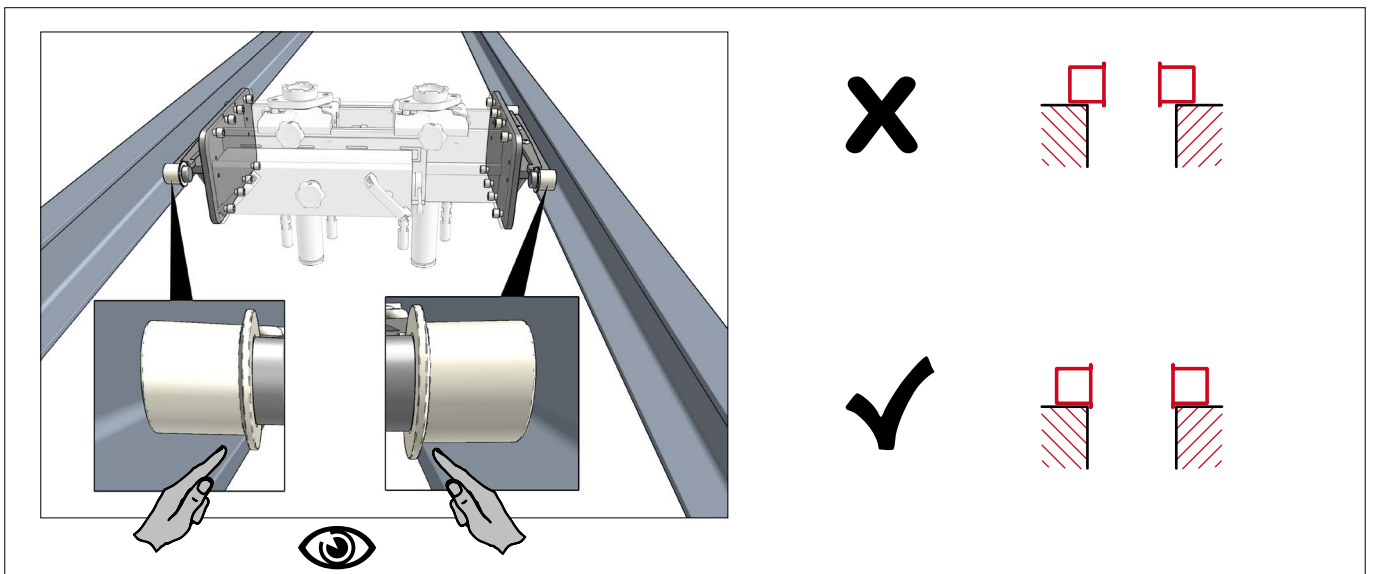
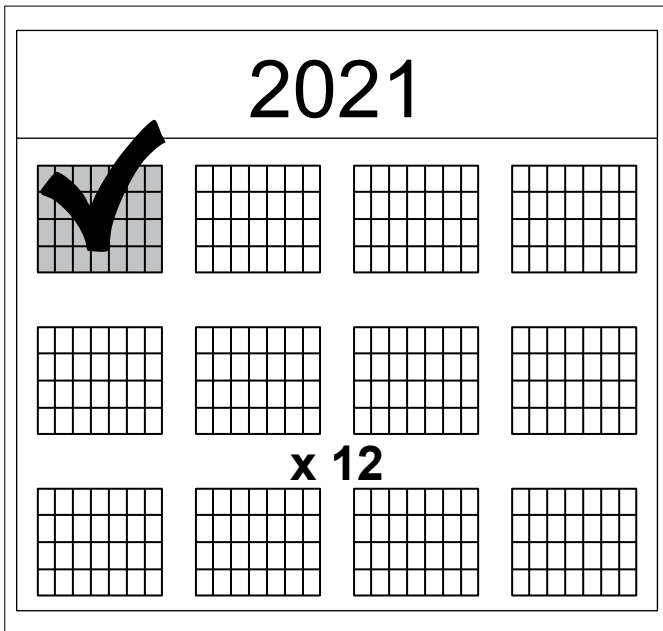

Fig.43



- ⓀⓃ Månedligt
- ⒼⓅ Monthly
- Ⓓⓔ Monatliche Inspektion
- ⒻⓇ Tous les mois
- Ⓢⓔ Varje månad
- ⒻⓂ Kerran kuukaudessa
- ⓃⓁ Maandelijks
- ⒺⓈ Mensualmente
- ⓇⓊ Ежемесячно
- ⒾⓉ Operazioni mensili

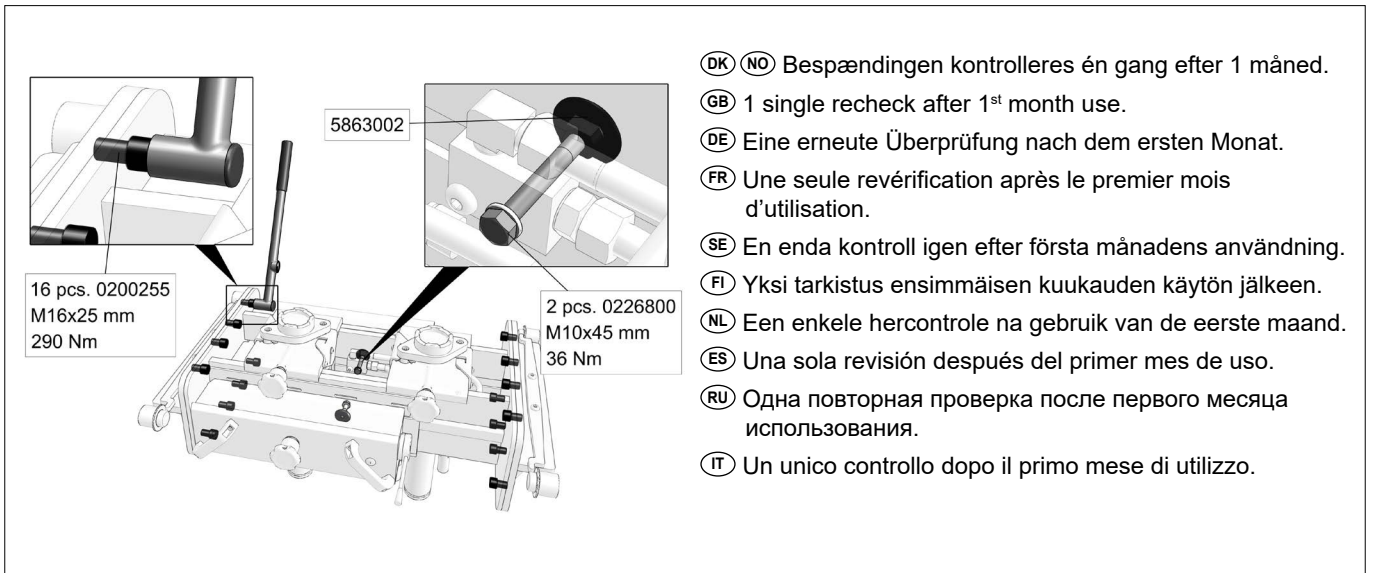

Fig.44

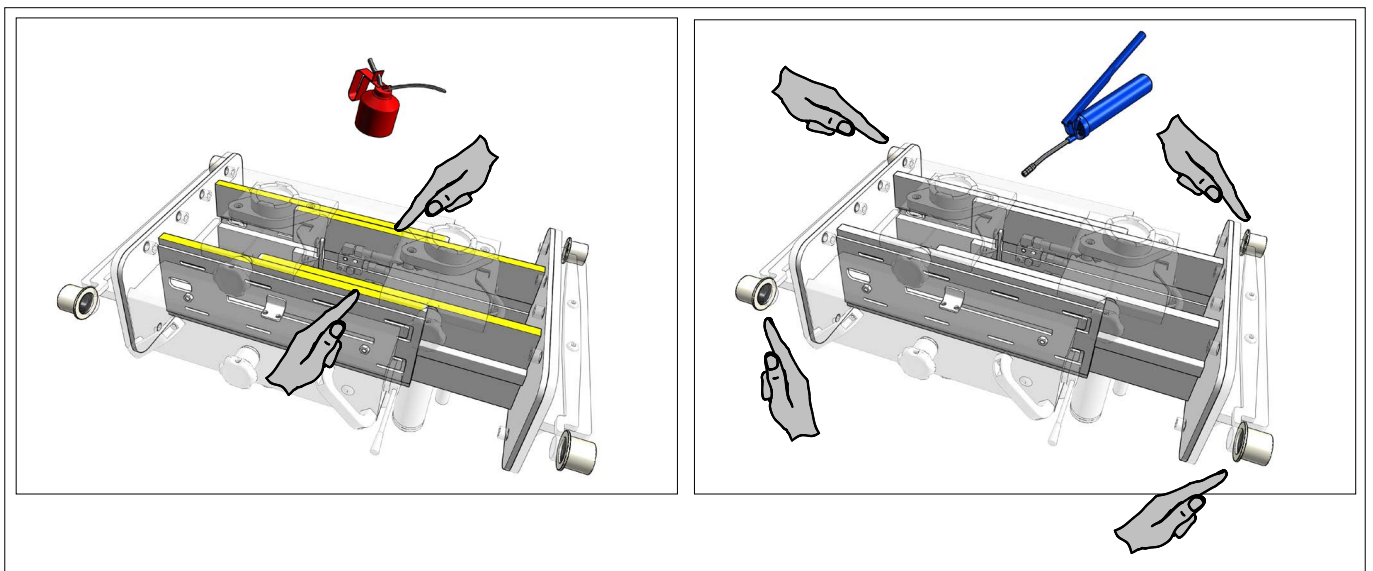

Fig.45

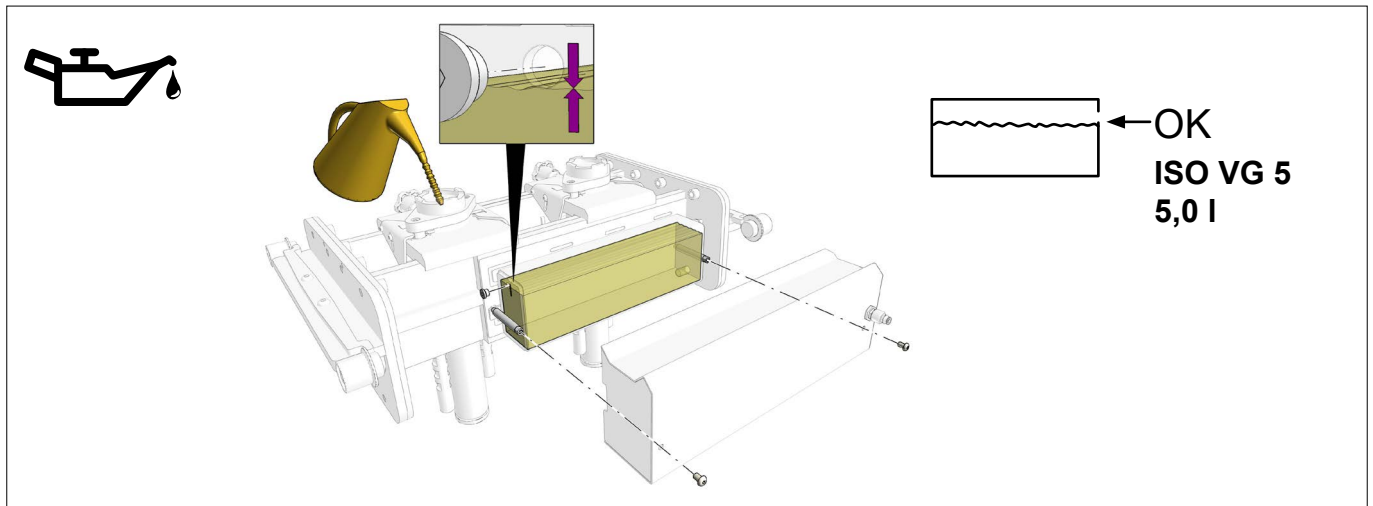
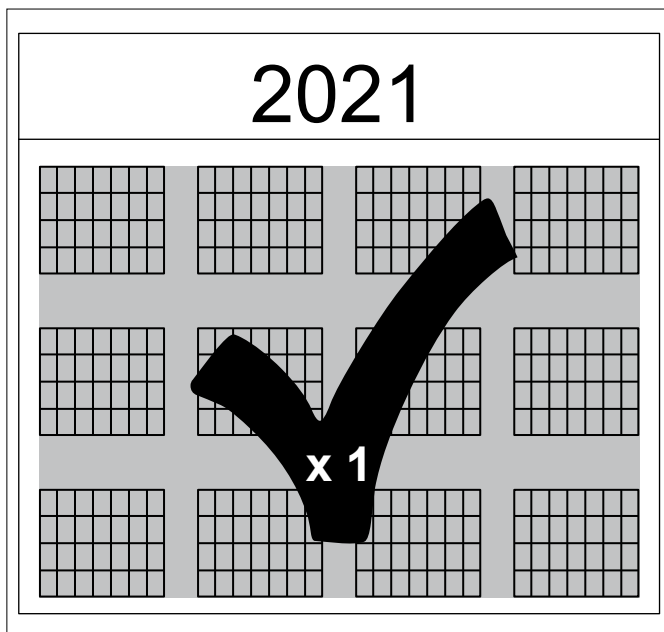

Fig. 46



(DK) Sikkerhedsmæssige eftersyn

I henhold til nationale bestemmelser – dog mindst en gang om året – skal følgende kontrolleres af en sagkyndig:

- Skader (Fig. 47) og unormalt slid
- Overtryksventilens funktion
- Slanger, cylindre og pumpe for utætheder (Fig. 48)
- Vand i olien (Fig. 49)
- Mærkater af sikkerhedsmæssig betydning er læsbare (Fig. 50).
- Justering og bespænding af låse og ophængsbolte (Fig. 51)

(GB) Safety Inspection

According to national legislation – at least once a year – the jack must be inspected by a professional for:

- Damage (Fig. 47), wear and tear
- Adjustment of the safety valve
- Hoses, cylinder and pump unit for leaks (Fig. 48)
- Presence of water in the reservoir (Fig. 49)
- Furthermore all safety labels must be checked to ensure that they are legible (Fig. 50).
- Adjustment of frame and torque setting of locks and support screws (Fig. 51).

(DE) Sicherheitsinspektion

Gemäß einschlägiger nationaler Bestimmungen, jedoch

mindestens einmal pro Jahr, sind folgende Punkte durch einen Sachkundigen zu überprüfen:

- Schäden (Fig. 47) und ungewöhnliche Abnutzung
- Einstellung des Überdruckventils
- Dichtigkeit von Schläuchen, Zylinder und Pumpe (Fig. 48)
- Wasser im Ölbehälter (Fig. 49)
- Lesbarkeit wichtiger Sicherheitshinweise (Fig. 50).
- Ausrichtung des Rahmens, fester Sitz der Sicherungsschrauben und Schrauben für die Aufhängung (Fig. 51).

(FR) Inspection de sécurité

Selon la législation nationale – au moins une fois par an – le cric et la selle de levage doivent être inspectés par un professionnel :

- Dommages (Fig. 47) et usure
- Réglage de la soupape de sécurité
- Flexibles, cylindre et pompe pour les fuites (Fig. 48)
- Présence d'eau dans un réservoir d'huile (Fig. 49).
- Toutes les étiquettes de sécurité doivent être vérifiées pour s'assurer qu'elles sont lisibles (Fig. 50).
- Réglage du cadre, serrage des attaches et des boulons de suspension (Fig. 51).

(SE) Säkerhetsunderhåll

Enligt nationella bestämmelser – dock minst en gång per år – måste domkraften kontrolleras av en sakkunnig med avseende på följande punkter:

- Slitage (Fig. 47)
- Justering av säkerhetsventiler
- Slangar, eventuellt läckage från cylinder och pumpenhet (Fig. 48)
- Vatten närvaro i oljetank (Fig. 49)
- Vidare måste alla säkerhetsdekaler kontrolleras för att säkerställa att de är läsbara (Fig. 50).
- Ramens justering och spänning av lås och upphängningsbulta (Fig. 51).

(FI) Turvatarkastukset

Asiantuntijan on tarkastettava nostimen toiminta kansallisten määräysten mukaan, kuitenkin vähintään kerran vuodessa:

- Vauriot (Fig. 47) ja yleinen kuluminen
- Varoventtiilin säätö
- Letkut, sylinterin ja pumpun vuodot (Fig. 48)
- Veden läsnäolo öljysäiliössä (Fig. 49)
- Myös kaikkien varoitustarvojen luettavuus on tarkastettava (Fig. 50).
- Asiantuntijan on tarkastettava rungon säädöt ja lukkojen sekä kiinnityspulttien kireys (Fig. 51).

NL Inspectie van de veiligheid

Volgens de nationale wetgeving moet de krik - ten minste een keer per jaar - worden gecontroleerd door een professional:

- Schade (Fig.47) en slijtage
- Afstelling van het veiligheidsventiel
- Slangen, cilinder en pompeenheid op lekken (Fig.48)
- Wateraanwezigheid in olietank (Fig.49).
- Bovendien moeten alle veiligheidslabels worden gecontroleerd om ervoor te zorgen dat ze leesbaar zijn (Fig.50).
- De afstelling van het frame en het aanhalen van de vergrendelingen en de ophangingsbouten (Fig.51).

ES Inspección de seguridad

De acuerdo con la legislación nacional, el elevador debe ser inspeccionado por un profesional al menos una vez al año. Deben inspeccionarse:

- Daños (Fig.47) y desgaste
- Ajuste de la válvula de seguridad
- Fugas en la unidad de la bomba, el cilindro y las mangueras (Fig.48)
- Presencia de agua en el tanque de aceite (Fig.49).
- Además, se deben comprobar todas las etiquetas de seguridad para asegurarse de que son legibles (Fig.50).
- Estado del bastidor y ajuste de los seguros y tornillos de los brazos de apoyo (Fig.51).

RU Проверка обеспечения безопасности

Согласно местному законодательству по крайней мере один раз в год домкрат должен проверяться специалистом на предмет наличия:

- Повреждений (Fig.47) и износа
- Правильности регулировки предохранительного клапана
- На предмет герметичности шлангов, цилиндра и насосного агрегата (Fig.48)
- Наличие воды в масляном баке (Fig.49).
- Кроме того, все предупреждающие этикетки должны проверяться на предмет их разборчивости (Fig.50).
- Проверка юстировки рамы и затяжки стопоров и крепежных болтов (Fig.51).

IT Controllo di sicurezza

In base alla normativa nazionale, almeno una volta l'anno è necessario sottoporre il sollevatore al controllo di un professionista, che verificherà la presenza di:

- Danni (Fig.47) e usura
- Regolazione della valvola di sicurezza
- Perdite dei tubi, dei cilindri e dell'unità di pompaggio (Fig.48)
- Presenza d'acqua nel serbatoio dell'olio (Fig.49).
- Inoltre, è necessario controllare l'integrità e la perfetta leggibilità di tutte le etichette di sicurezza (Fig.50).
- Regolazione del telaio e regolazione della coppia di serrature e viti di supporto (Fig.51).

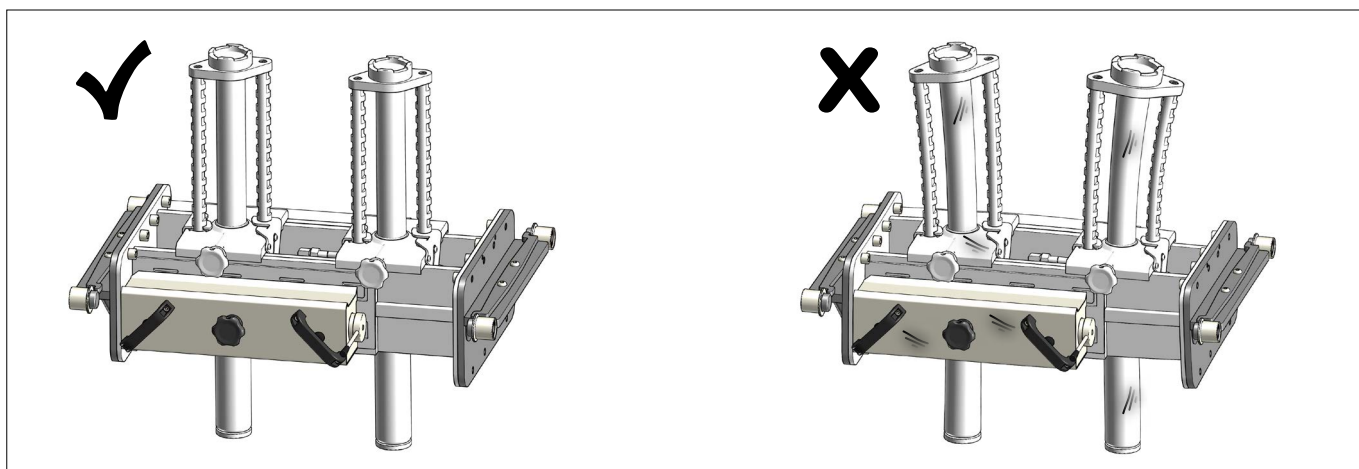

Fig.47

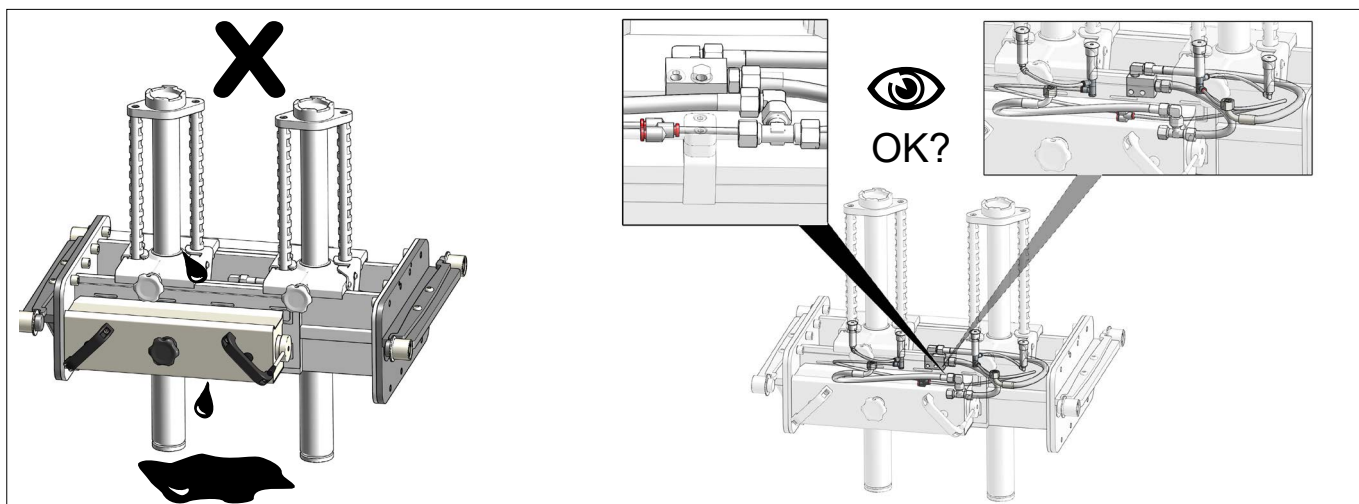

Fig.48

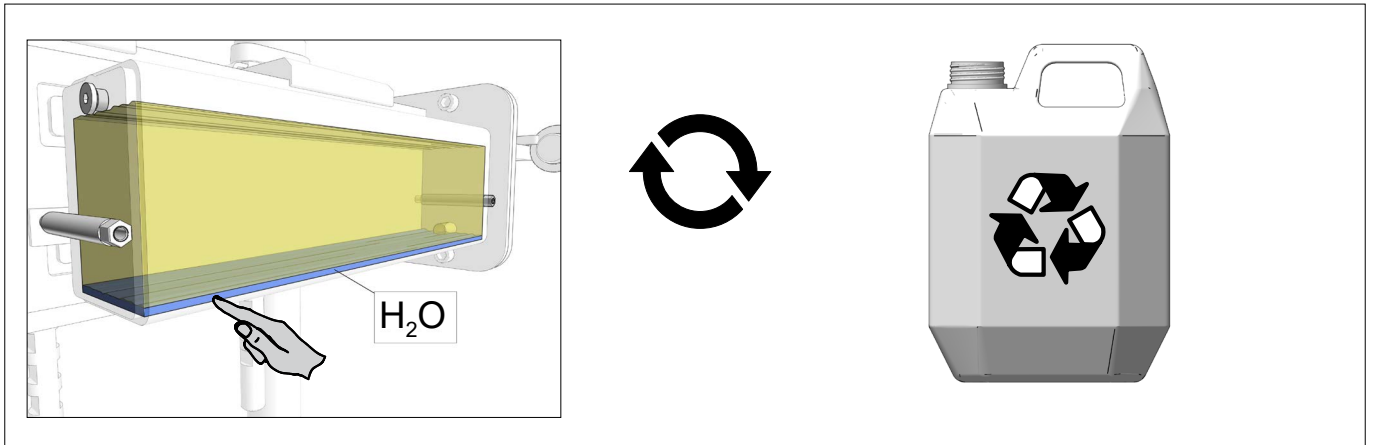

Fig.49

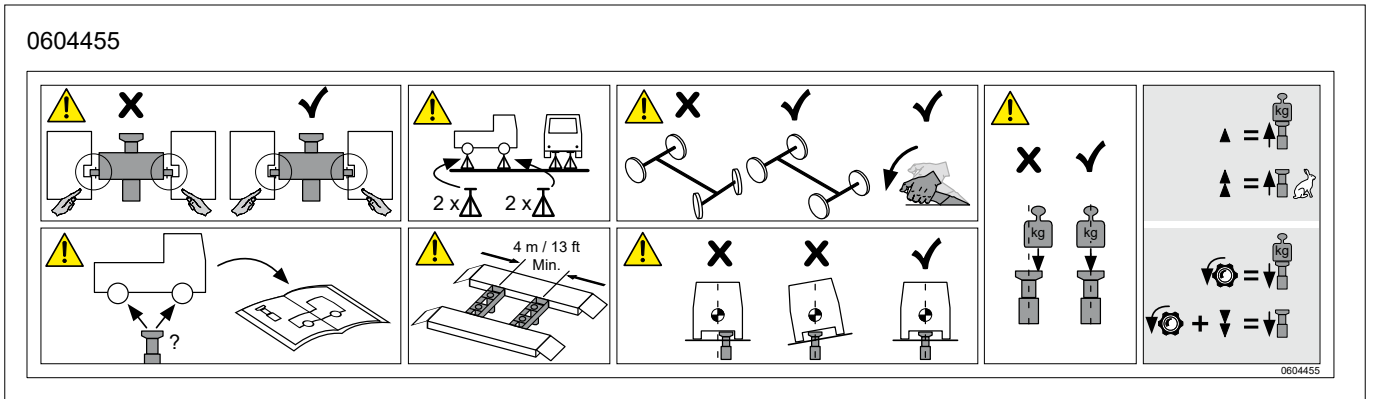

Fig.50

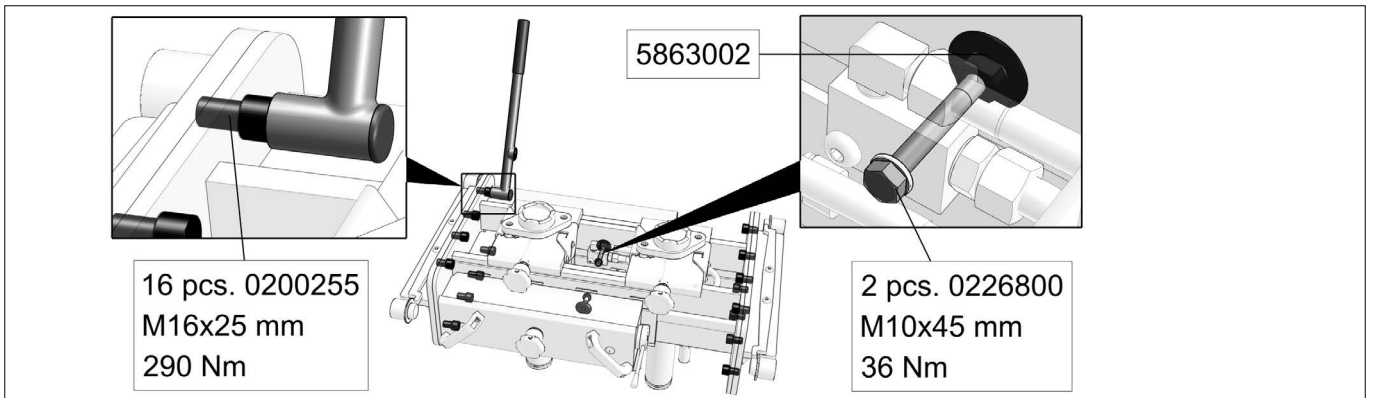

Fig.51

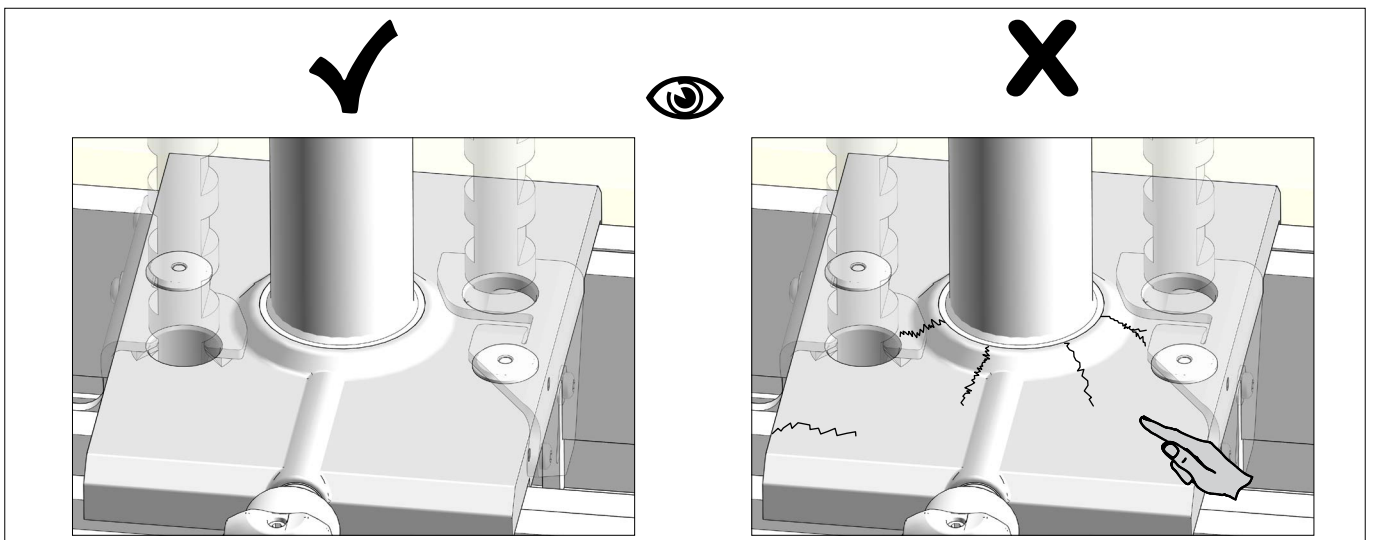
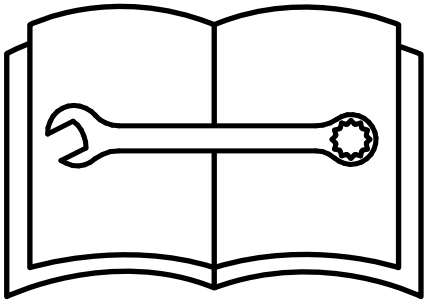

Fig.52



- Ⓚ NO Fejlfinding
- Ⓒ GB Troubleshooting
- Ⓓ DE Fehlersuche und -behebung
- Ⓕ FR Guide de dépannage
- Ⓔ SE Felsökning
- Ⓕ FI Vianmääritys
- Ⓖ NL Storingzoeken
- Ⓔ ES Solución de problemas
- Ⓒ RU Диагностика неисправностей
- Ⓖ IT Risoluzione dei problemi

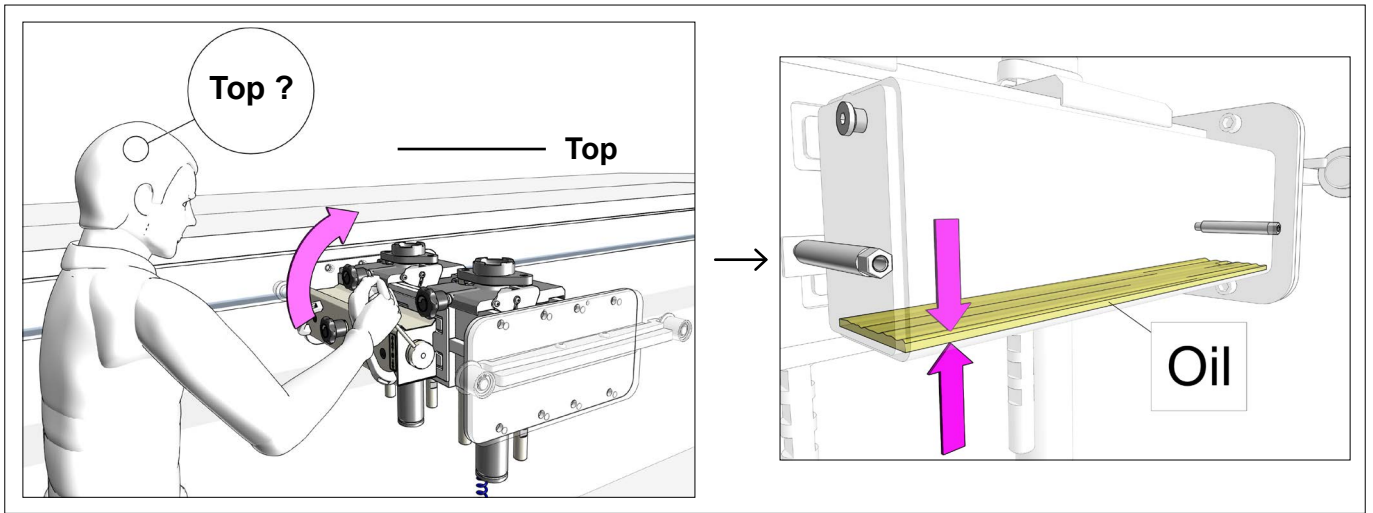

Fig.53

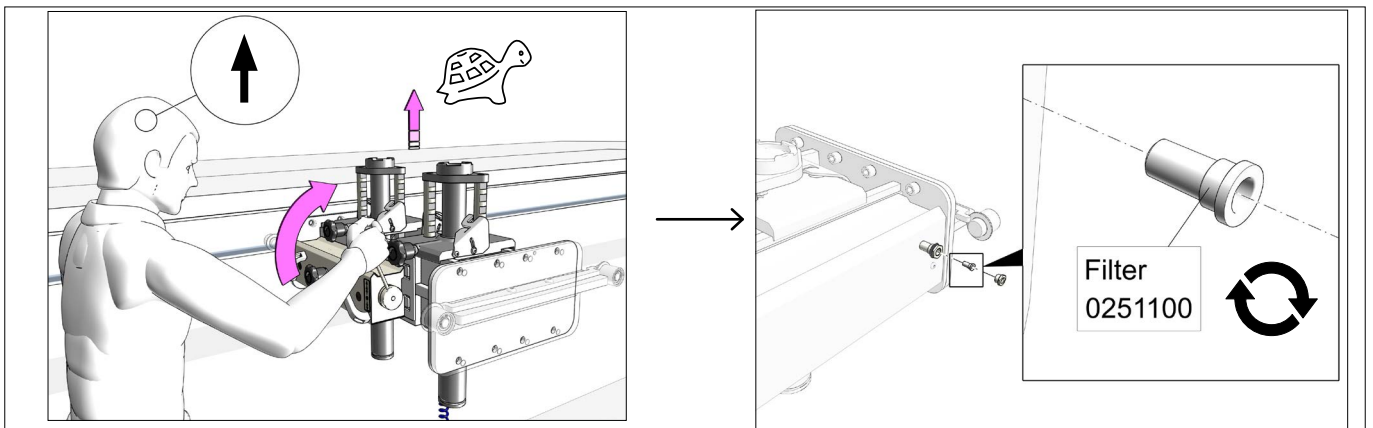

Fig.54

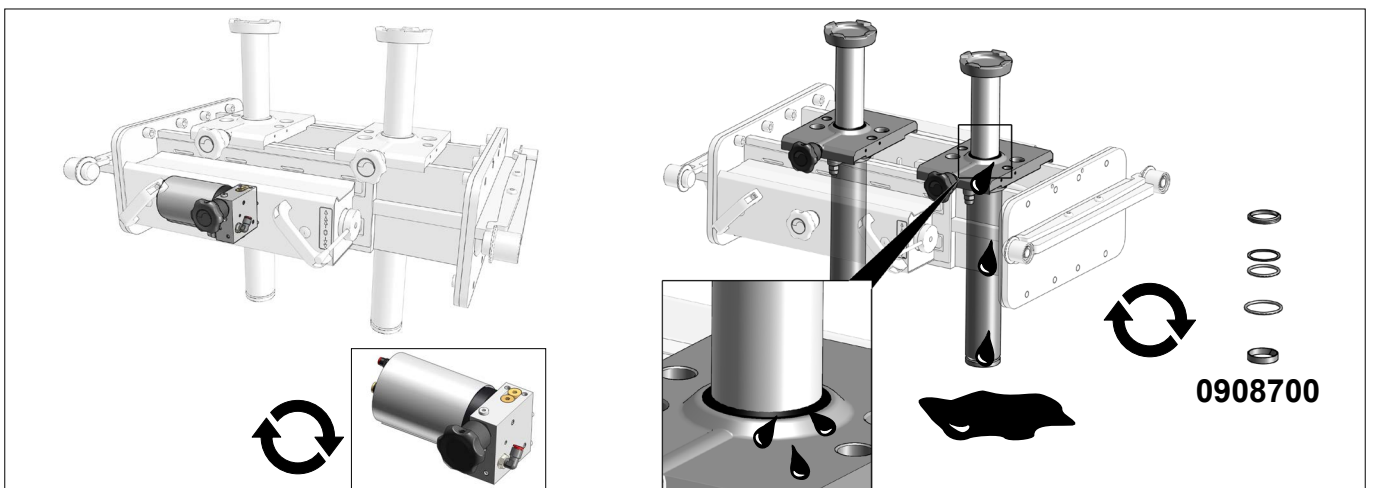

Fig.55

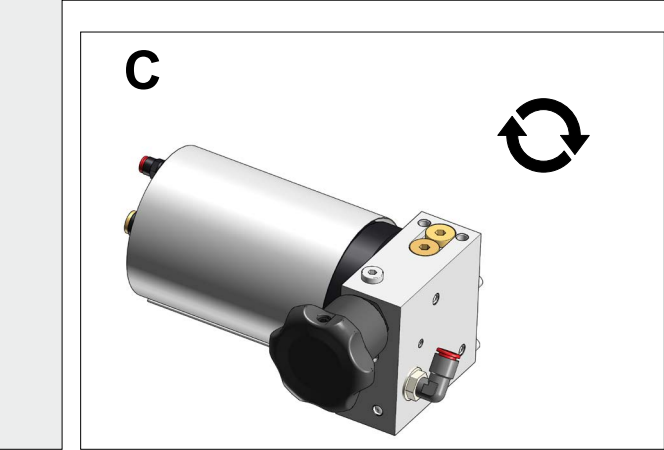
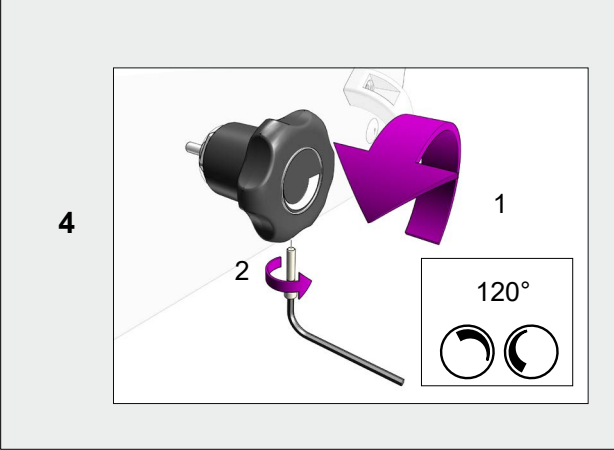
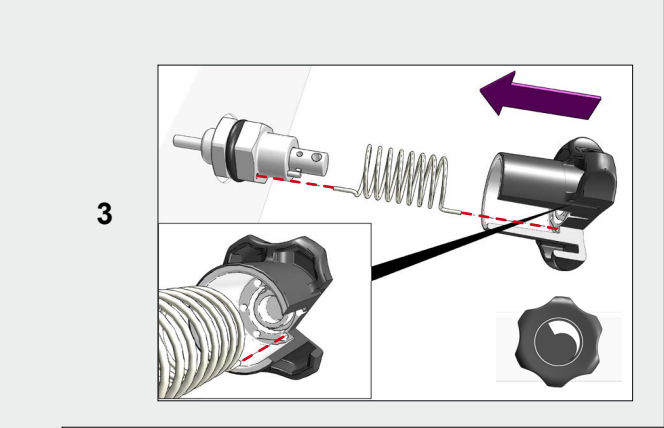
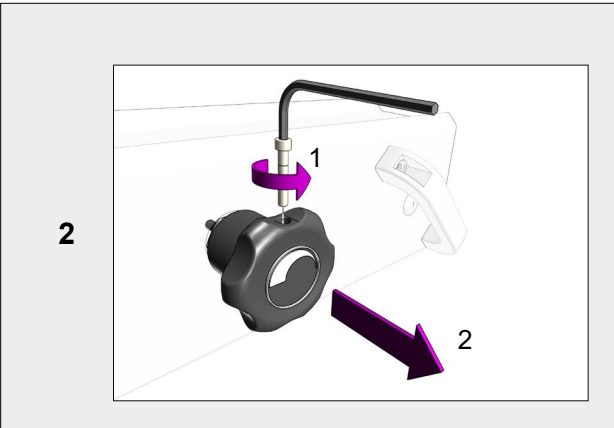
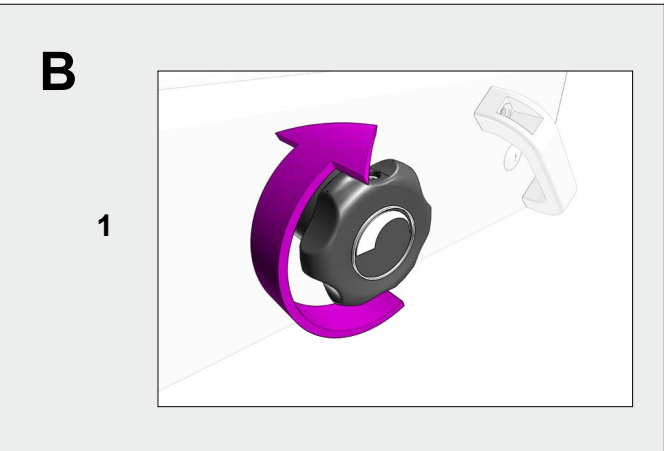
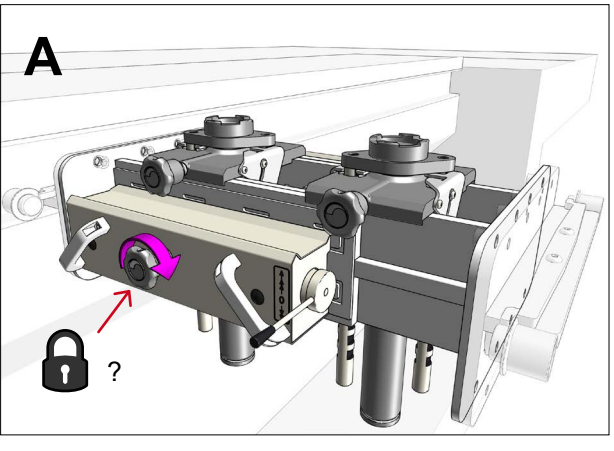
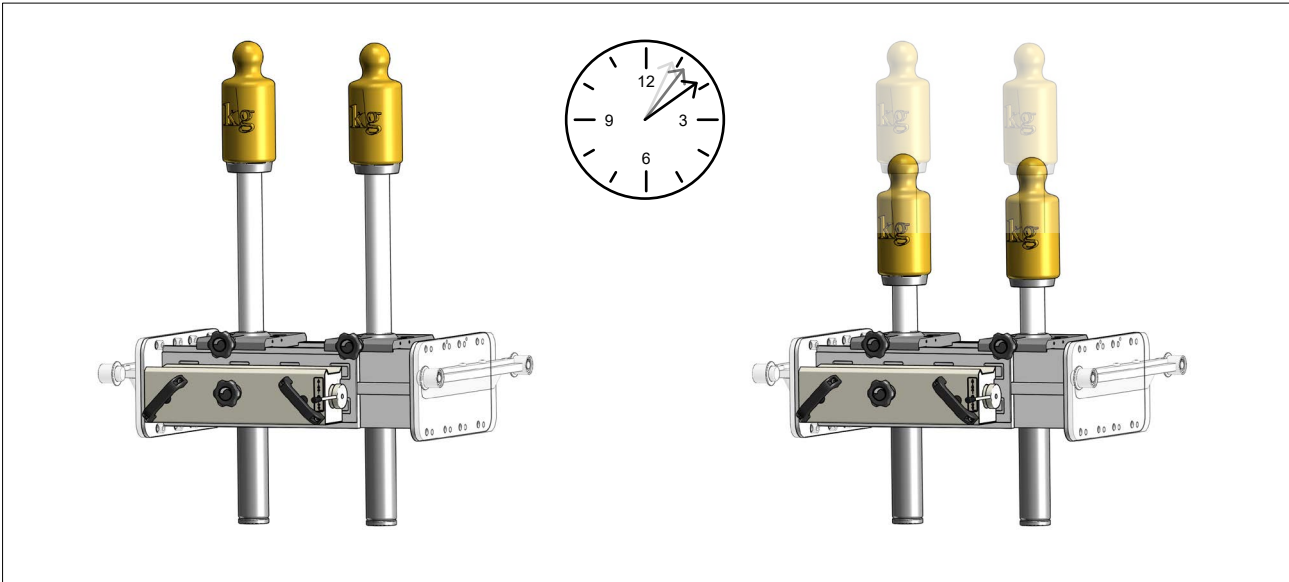
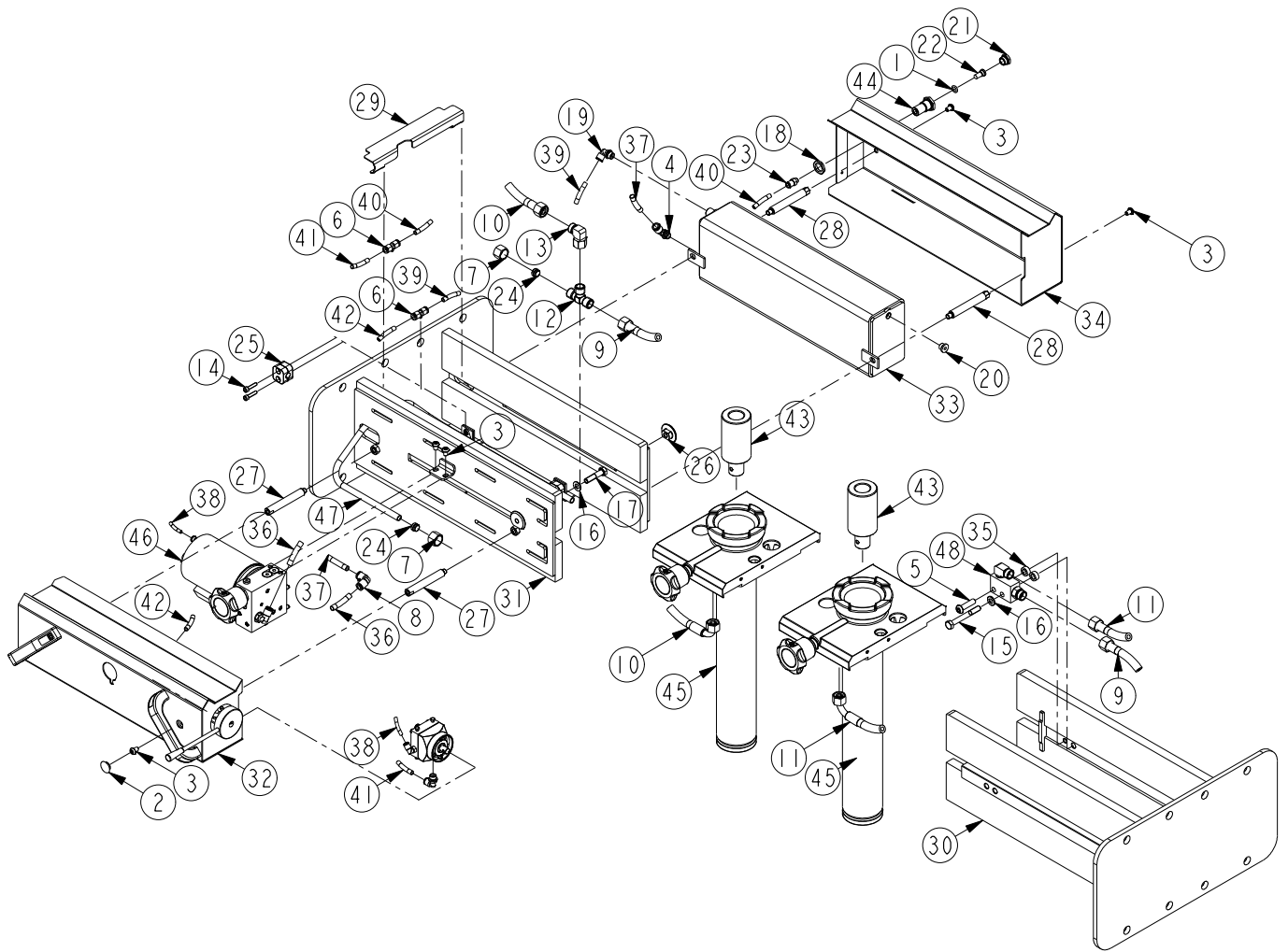
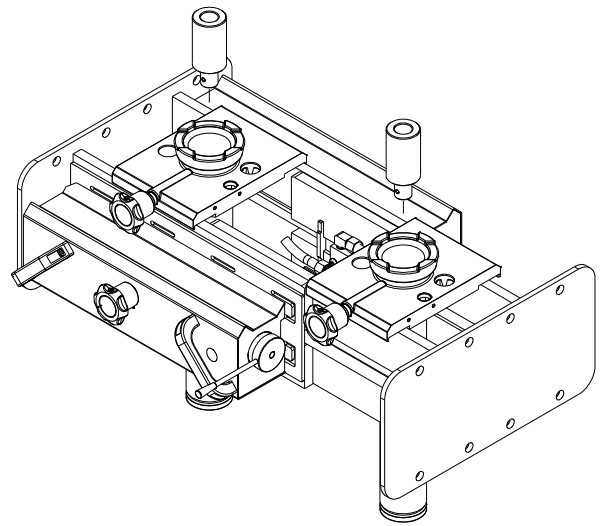

Fig.56

GD-2 FL-2



Pos.	GD-2K	GD-2L	FL-2K	FL-2L	Pcs.	(DK)	(GB)	(DE)
	Art. No.	Art. No.	Art. No.	Art. No.		Benævnelse	Description	Bezeichnung
	58 714 xx	58 724 xx				Gravdonkraft	Pit jack	Grubenheber
			58 713 xx	58 723 xx		Frihjulsløfter	Jacking beam	Achsfreiheber
1	01 000 00	01 000 00	01 000 00	01 000 00	1	O-ring	O-ring	O-Ring
2	02 001 30	02 001 30	02 001 30	02 001 30	2	Prop	Plug	Pfropfen
3	02 001 43	02 001 43	02 001 43	02 001 43	6	Skruer	Screw	Schraube
4	02 002 49	02 002 49	02 002 49	02 002 49	1	Fitting	Fitting	Fitting
5	02 002 51	02 002 51	02 002 51	02 002 51	1	Skruer	Screw	Schraube
6	02 002 61	02 002 61	02 002 61	02 002 61	2	Fitting	Fitting	Fitting
7	02 002 84	02 002 84	02 002 84	02 002 84	2	Omløber	Union nut	Überwurfmutter
8	02 002 86	02 002 86	02 002 86	02 002 86	1	Fitting	Fitting	Fitting
9	02 005 36	02 005 36	02 005 36	02 005 36	1	Hydraulikslange	Hose	Schlauch
10	02 005 37	02 005 38	02 005 37	02 005 38	1	Hydraulikslange	Hose	Schlauch
11	02 005 37	02 005 38	02 005 37	02 005 38	1	Hydraulikslange	Hose	Schlauch
12	02 005 44	02 005 44	02 005 44	02 005 44	1	Fitting	Fitting	Fitting
13	02 005 45	02 005 45	02 005 45	02 005 45	1	Fitting	Fitting	Fitting
14	02 084 00	02 084 00	02 084 00	02 084 00	4	Skruer	Screw	Schraube
15	02 092 00	02 002 51	02 092 00	02 002 51	1	Skruer	Screw	Schraube
16	02 116 00	02 116 00	02 116 00	02 116 00	2	Skive	Washer	Scheibe
17	02 268 00	02 268 00	02 268 00	02 268 00	1/2	Skruer	Screw	Schraube
18	02 436 00	02 436 00	02 436 00	02 436 00	1	Møtrik	Nut	Mutter
19	02 439 00	02 439 00	02 439 00	02 439 00	1	Fitting	Fitting	Fitting
20	02 470 00	02 470 00	02 470 00	02 470 00	1	Prop	Plug	Pfropfen
21	02 506 00	02 506 00	02 506 00	02 506 00	1	Fitting	Fitting	Fitting
22	02 511 00	02 511 00	02 511 00	02 511 00	1	Filter	Filter	Filter
23	02 516 00	02 516 00	02 516 00	02 516 00	1	Fitting	Fitting	Fitting
24	02 752 00	02 752 00	02 752 00	02 752 00	2	Skærring	Ring	Ring
25	02 857 00	02 857 00	02 857 00	02 857 00	2	Rørholder	Clamp	Rohrhalter
26	58 630 02	58 630 02	58 630 02	58 630 02	2	Bøsning	Bush	Buchse
27	58 630 05	58 630 05	58 630 05	58 630 05	2	Støttebolt	Stud	Stehbolzen
28	58 630 06	58 630 06	58 630 06	58 630 06	2	Støttebolt	Stud	Stehbolzen
29	58 630 28	58 630 28	58 630 28	58 630 28	1	Skærm	Cover	Schirm
30	58 631 10	58 632 10	58 631 10	58 632 10	1	Inderkonsol	Console, inner	Hauptrahmen, innen
31	58 631 20	58 632 20	58 631 20	58 632 20	1	Yderkonsol	Console, outer	Hauptrahmen, aussen
32	58 651 10	58 651 10	58 651 10	58 651 10	1	Betjeningspanel	Operation panel	Bedienfeld
33	58 652 15	58 652 15	58 652 15	58 652 15	1	Olietank	Reservoir	Ölbehälter
34	58 653 10	58 653 10	58 653 10	58 653 10	1	Tankpanel	Cover, rear	Schirm, hinter
35	62 314 10	62 314 10	62 314 10	62 314 10	2	Afstandsøsning	Distancebushing	Swishenrohr
36	90 791 07	90 791 07	90 791 07	90 791 07	1	Luftslange	Hose	Schlauch
37	90 791 65	90 791 65	90 791 65	90 791 65	1	Luftslange	Hose	Schlauch
38	90 796 70	90 796 70	90 796 70	90 796 70	1	Luftslange	Hose	Schlauch
39	90 798 12	90 798 12	90 798 12	90 798 12	1	Luftslange	Hose	Schlauch
40	90 798 26	90 798 26	90 798 26	90 798 26	1	Luftslange	Hose	Schlauch
41	90 798 60	90 798 60	90 798 60	90 798 60	1	Luftslange	Hose	Schlauch
42	90 798 67	90 798 67	90 798 67	90 798 67	1	Luftslange	Hose	Schlauch
43	91 141 00	91 141 00	91 141 00	91 141 00	2	Forlænger	Extension	Verlängerung
44	91 206 00	91 206 00	91 206 00	91 206 00	1	Filterhus	Filtercasing	Gehäuse für Filter
45	91 604 00	91 604 00	91 603 00	91 603 00	2	Cylinder, kpl.	Cylinder, complete	Zylinder, komplett
46	91 605 xx	91 605 xx	91 605 xx	91 605 xx	1	Pumpe, kpl.	Pump, complete	Pumpe, komplett
47	91 605 06	91 605 05	91 605 06	91 605 05	1	Hydraulikrør	Tube	Rohr
48	91 605 10	91 605 10	91 605 10	91 605 10	1	Manifold	Manifold	Verteiler

DK: Anvend altid originale reservedele. Angiv venligst altid model og reservedelsnummer. Alle hoveddele kan ikke forventes leveret efter produktionsophør.

GB: Please always state model and part number. Do always apply original spare parts.

All major parts may not be provided as spare parts after discontinuation of production of a model.

DE: Bitte immer Modell und Ersatzteilnummer auf Ihren Bestellungen angeben. Immer nur Originalteile verwenden. Lieferung von allen Hauptteilen als Ersatzteile kann nach Produktions-Einstellung eines Modelles nicht erwartet werden.

GD-2W FL-2W

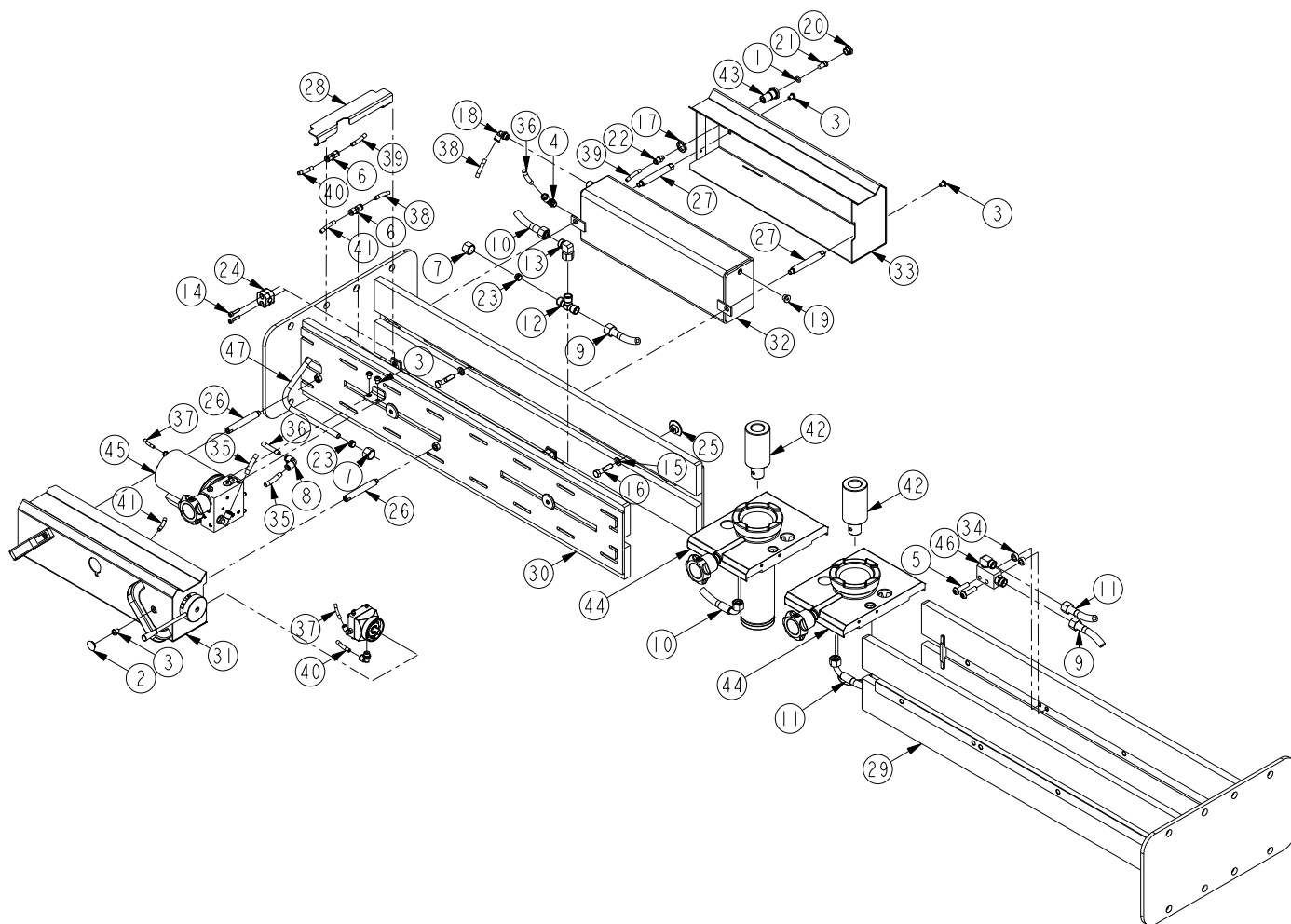
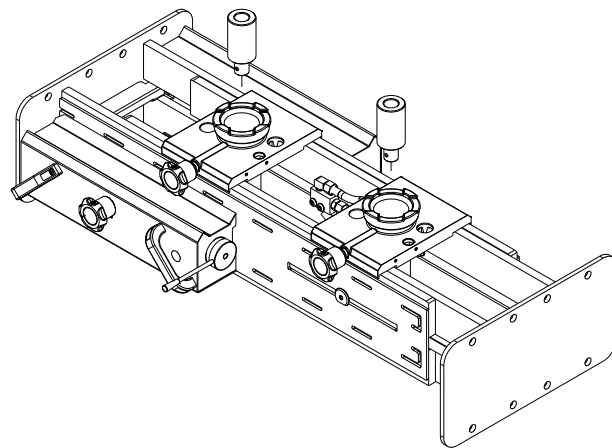

Pos.	GD-2W	FL-2W	(DK)	(GB)	(DE)
	Art. No.	Art. No.	Pcs. Benævnelse	Description	Bezeichnung
	58 734 xx		Gravdonkraft W	Pit jack W	Grubenheber W
		58 733 xx	Frihjulsløfter W	Jacking beam W	Achsfreiheber W
1	01 000 00	01 000 00	1 O-ring	O-ring	O-Ring
2	02 001 30	02 001 30	2 Prop	Plug	Pfropfen
3	02 001 43	02 001 43	6 Skrue	Screw	Schraube
4	02 002 49	02 002 49	1 Fitting	Fitting	Fitting
5	02 002 51	02 002 51	2 Skrue	Screw	Schraube
6	02 002 61	02 002 61	2 Fitting	Fitting	Fitting
7	02 002 84	02 002 84	2 Omløber	Union nut	Überwurfmutter
8	02 002 86	02 002 86	1 Fitting	Fitting	Fitting
9	02 005 36	02 005 36	1 Hydraulikslange	Hose	Schlauch
10	02 005 39	02 005 39	1 Hydraulikslange	Hose	Schlauch
11	02 005 39	02 005 39	1 Hydraulikslange	Hose	Schlauch
12	02 005 44	02 005 44	1 Fitting	Fitting	Fitting
13	02 005 45	02 005 45	1 Fitting	Fitting	Fitting
14	02 084 00	02 084 00	4 Skrue	Screw	Schraube
15	02 116 00	02 116 00	4 Skive	Disc	Scheibe
16	02 268 00	02 268 00	4 Skrue	Screw	Schraube
17	02 436 00	02 436 00	1 Møtrik	Nut	Mutter
18	02 439 00	02 439 00	1 Fitting	Fitting	Fitting
19	02 470 00	02 470 00	1 Prop	Plug	Pfropfen
20	02 506 00	02 506 00	1 Fitting	Fitting	Fitting
21	02 511 00	02 511 00	1 Filter	Filter	Filter
22	02 516 00	02 516 00	1 Fitting	Fitting	Fitting
23	02 752 00	02 752 00	2 Skæring	Ring	Ring
24	02 857 00	02 857 00	2 Rørholder	Clamp	Rohrhalter
25	58 630 02	58 630 02	4 Bøsning	Bush	Buchse
26	58 630 05	58 630 05	2 Støttebolt	Stud	Stehbolzen
27	58 630 06	58 630 06	2 Støttebolt	Stud	Stehbolzen
28	58 630 28	58 630 28	1 Skærm	Cover	Schirm
29	58 633 10	58 633 10	1 Inderkonsol	Console, inner	Haupttrahmen, innen
30	58 633 20	58 633 20	1 Yderkonsol	Console, outer	Haupttrahmen, aussen
31	58 651 10	58 651 10	1 Betjeningspanel	Operation panel	Bedienfeld
32	58 652 15	58 652 15	1 Olietank	Reservoir	Ölbehälter
33	58 653 10	58 653 10	1 Tankpanel	Cover, rear	Schirm, hinter
34	62 314 10	62 314 10	2 Afstandsbøsning	Distancebushing	Swishenrohr
35	90 791 07	90 791 07	1 Luftslange	Hose	Schlauch
36	90 791 65	90 791 65	1 Luftslange	Hose	Schlauch
37	90 796 70	90 796 70	1 Luftslange	Hose	Schlauch
38	90 798 12	90 798 12	1 Luftslange	Hose	Schlauch
39	90 798 26	90 798 26	1 Luftslange	Hose	Schlauch
40	90 798 60	90 798 60	1 Luftslange	Hose	Schlauch
41	90 798 67	90 798 67	1 Luftslange	Hose	Schlauch
42	91 141 00	91 141 00	2 Forlænger	Extension	Verlängerung
43	91 206 00	91 206 00	1 Filterhus	Filtercasing	Gehäuse für Filter
44	91 604 00	91 603 00	2 Cylinder, kpl.	Cylinder, complete	Zylinder, komplett
45	91 605 xx	91 605 xx	1 Pumpe, kpl.	Pump, complete	Pumpe, komplett
46	91 605 10	91 605 10	1 Manifold	Manifold	Verteiler
47	91 605 12	91 605 12	1 Hydraulikrør	Tube	Rohr

DK: Anvend altid originale reservedele. Angiv venligst altid model og reservedelsnummer. Alle hoveddele kan ikke forventes leveret efter produktionsophør.

GB: Please always state model and part number. Do always apply original spare parts.

All major parts may not be provided as spare parts after discontinuation of production of a model.

DE: Bitte immer Modell und Ersatzteilnummer auf Ihren Bestellungen angeben. Immer nur Originalteile verwenden. Lieferung von allen Hauptteilen als Ersatzteile kann nach Produktions-Einstellung eines Modelles nicht erwartet werden.

GD-2MK
GD-2ML
GD-2MW

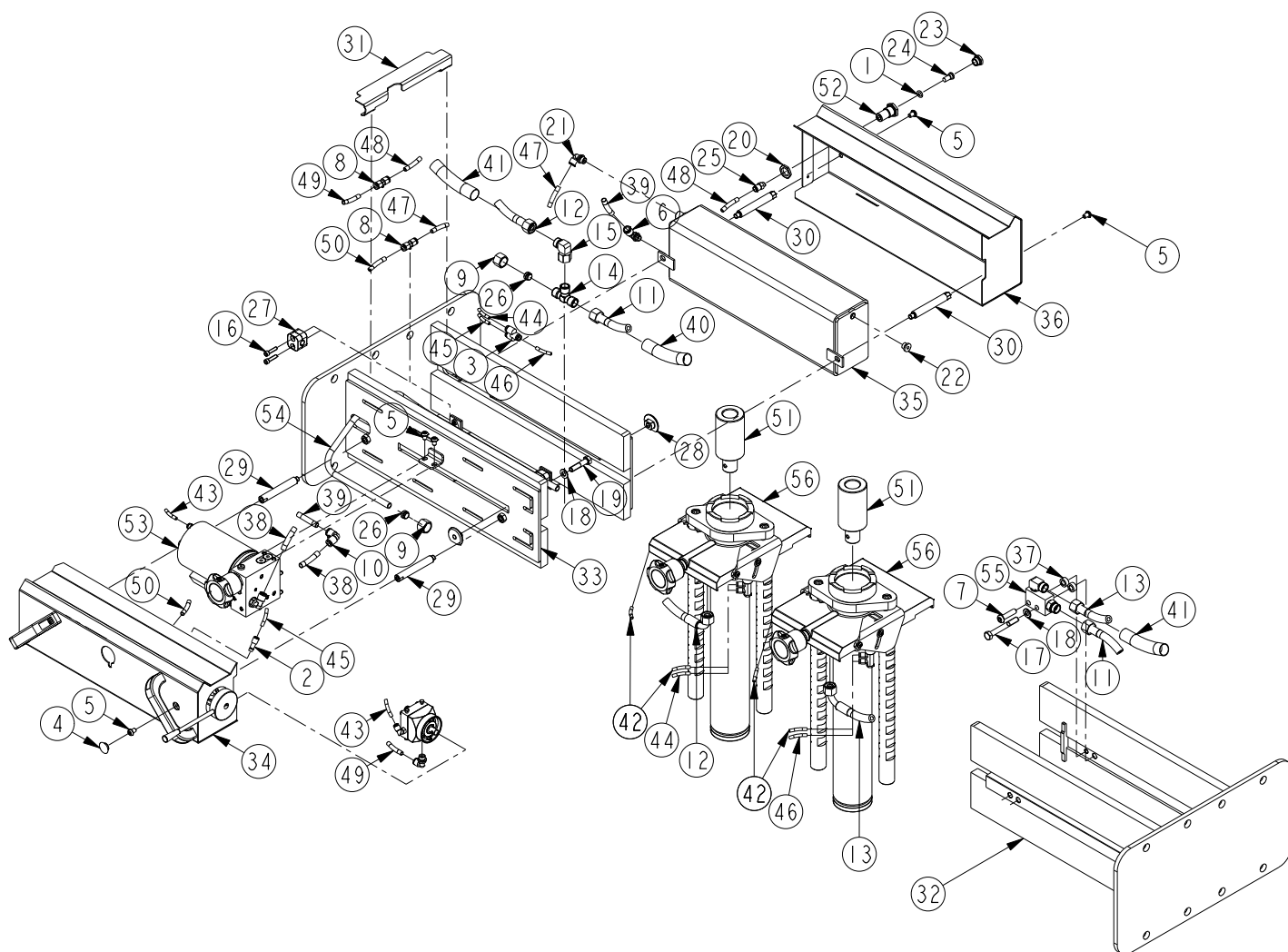
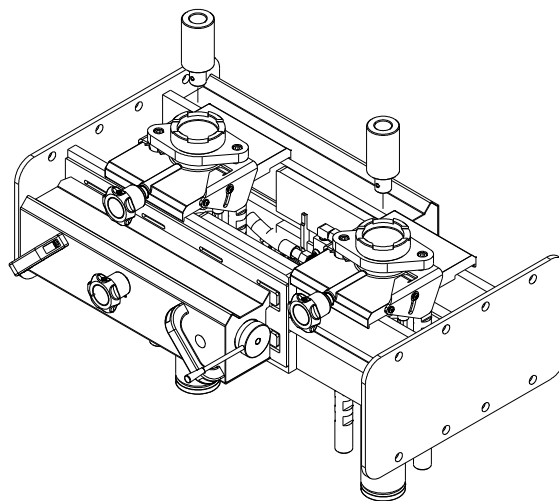

	GD-2MK	GD-2ML	GD-2MW		(DK)	(GB)	(DE)
Pos.	Art. No.	Art. No.	Art. No.	Pcs.	Benævnelse	Description	Bezeichnung
	58 764 xx	58 774 xx	58 784 xx		Gravdonkraft	Pit jack	Grubenheber
1	01 000 00	01 000 00	01 000 00	1	O-ring	O-ring	O-Ring
2	02 000 37	02 000 37	02 000 37	1	Fitting	Fitting	Fitting
3	02 000 42	02 000 42	02 000 42	1	Fitting	Fitting	Fitting
4	02 001 30	02 001 30	02 001 30	2	Prop	Plug	Pfropfen
5	02 001 43	02 001 43	02 001 43	6	Skrue	Screw	Schraube
6	02 002 49	02 002 49	02 002 49	1	Fitting	Fitting	Fitting
7	02 002 51	02 002 51	02 002 51	1	Skrue	Screw	Schraube
8	02 002 61	02 002 61	02 002 61	2	Fitting	Fitting	Fitting
9	02 002 84	02 002 84	02 002 84	2	Omløber	Union nut	Überwurfmutter
10	02 002 86	02 002 86	02 002 86	1	Fitting	Fitting	Fitting
11	02 005 36	02 005 36	02 005 36	1	Hydraulikslange	Hose	Schlauch
12	02 005 37	02 005 38	02 005 39	1	Hydraulikslange	Hose	Schlauch
13	02 005 37	02 005 38	02 005 39	1	Hydraulikslange	Hose	Schlauch
14	02 005 44	02 005 44	02 005 44	1	Fitting	Fitting	Fitting
15	02 005 45	02 005 45	02 005 45	1	Fitting	Fitting	Fitting
16	02 084 00	02 084 00	02 084 00	4	Skrue	Screw	Schraube
17	02 092 00	02 002 51	02 002 51	1	Skrue	Screw	Schraube
18	02 116 00	02 116 00	02 116 00	2/4	Skive	Washer	Scheibe
19	02 268 00	02 268 00	02 268 00	1/2/4	Skrue	Screw	Schraube
20	02 436 00	02 436 00	02 436 00	1	Møtrik	Nut	Mutter
21	02 439 00	02 439 00	02 439 00	1	Fitting	Fitting	Fitting
22	02 470 00	02 470 00	02 470 00	1	Prop	Plug	Pfropfen
23	02 506 00	02 506 00	02 506 00	1	Fitting	Fitting	Fitting
24	02 511 00	02 511 00	02 511 00	1	Filter	Filter	Filter
25	02 516 00	02 516 00	02 516 00	1	Fitting	Fitting	Fitting
26	02 752 00	02 752 00	02 752 00	2	Skæring	Ring	Ring
27	02 857 00	02 857 00	02 857 00	2	Rørholder	Clamp	Rohrhalter
28	58 630 02	58 630 02	58 630 02	2/4	Bøsning	Bush	Buchse
29	58 630 05	58 630 05	58 630 05	2	Støttebolt	Stud	Stehbolzen
30	58 630 06	58 630 06	58 630 06	2	Støttebolt	Stud	Stehbolzen
31	58 630 28	58 630 28	58 630 28	1	Skærm	Cover	Schirm
32	58 631 10	58 632 10	58 633 10	1	Inderkonsol	Console, inner	Hauptrahmen, innen
33	58 631 20	58 632 20	58 633 20	1	Yderkonsol	Console, outer	Hauptrahmen, aussen
34	58 651 10	58 651 10	58 651 10	1	Betjeningspanel	Operation panel	Bedienfeld
35	58 652 15	58 652 15	58 652 15	1	Olietank	Reservoir	Ölbehälter
36	58 653 10	58 653 10	58 653 10	1	Tankpanel	Cover, rear	Schirm, hinter
37	62 314 10	62 314 10	62 314 10	2	Afstandsbøsning	Distancebushing	Swishenrohr
38	90 791 07	90 791 07	90 791 07	1	Luftslange	Hose	Schlauch
39	90 791 65	90 791 65	90 791 65	1	Luftslange	Hose	Schlauch
40	90 792 50	90 792 50	90 792 50	1	Strømpeflex	Hose stocking	Strumpf
41	90 792 50	90 792 65	90 792 80	2	Strømpeflex	Hose stocking	Strumpf
42	90 796 18	90 796 18	90 796 18	2	Luftslange	Hose	Schlauch
43	90 796 70	90 796 70	90 796 70	1	Luftslange	Hose	Schlauch
44	90 796 75	90 797 00	90 797 05	1	Luftslange	Hose	Schlauch
45	90 796 90	90 797 00	90 797 13	1	Luftslange	Hose	Schlauch
46	90 797 20	90 797 20	90 797 20	1	Luftslange	Hose	Schlauch
47	90 798 12	90 798 12	90 798 12	1	Luftslange	Hose	Schlauch
48	90 798 26	90 798 26	90 798 26	1	Luftslange	Hose	Schlauch
49	90 798 60	90 798 60	90 798 60	1	Luftslange	Hose	Schlauch
50	90 798 67	90 798 67	90 798 67	1	Luftslange	Hose	Schlauch
51	91 141 00	91 141 00	91 141 00	2	Forlænger	Extension	Verlängerung
52	91 206 00	91 206 00	91 206 00	1	Filterhus	Filtercasing	Gehäuse für Filter
53	91 605 xx	91 605 xx	91 605 xx	1	Pumpe, kpl.	Pump, complete	Pumpe, komplett
54	91 605 06	91 605 05	91 605 12	1	Hydraulikrør	Tube	Rohr
55	91 605 10	91 605 10	91 605 10	1	Manifold	Manifold	Verteiler
56	91 607 00	91 607 00	91 607 00	2	Cylinder, kpl.	Cylinder, complete	Zylinder, komplett

DK: Anvend altid originale reservedele. Angiv venligst altid model og reservedelsnummer. Alle hoveddele kan ikke forventes leveret efter produktionsophør.

GB: Please always state model and part number. Do always apply original spare parts.

All major parts may not be provided as spare parts after discontinuation of production of a model.

DE: Bitte immer Modell und Ersatzteilnummer auf Ihren Bestellungen angeben. Immer nur Originalteile verwenden. Lieferung von allen Hauptteilen als Ersatzteile kann nach Produktions-Einstellung eines Modelles nicht erwartet werden.

FL-2MK
FL-2ML
FL-2MW

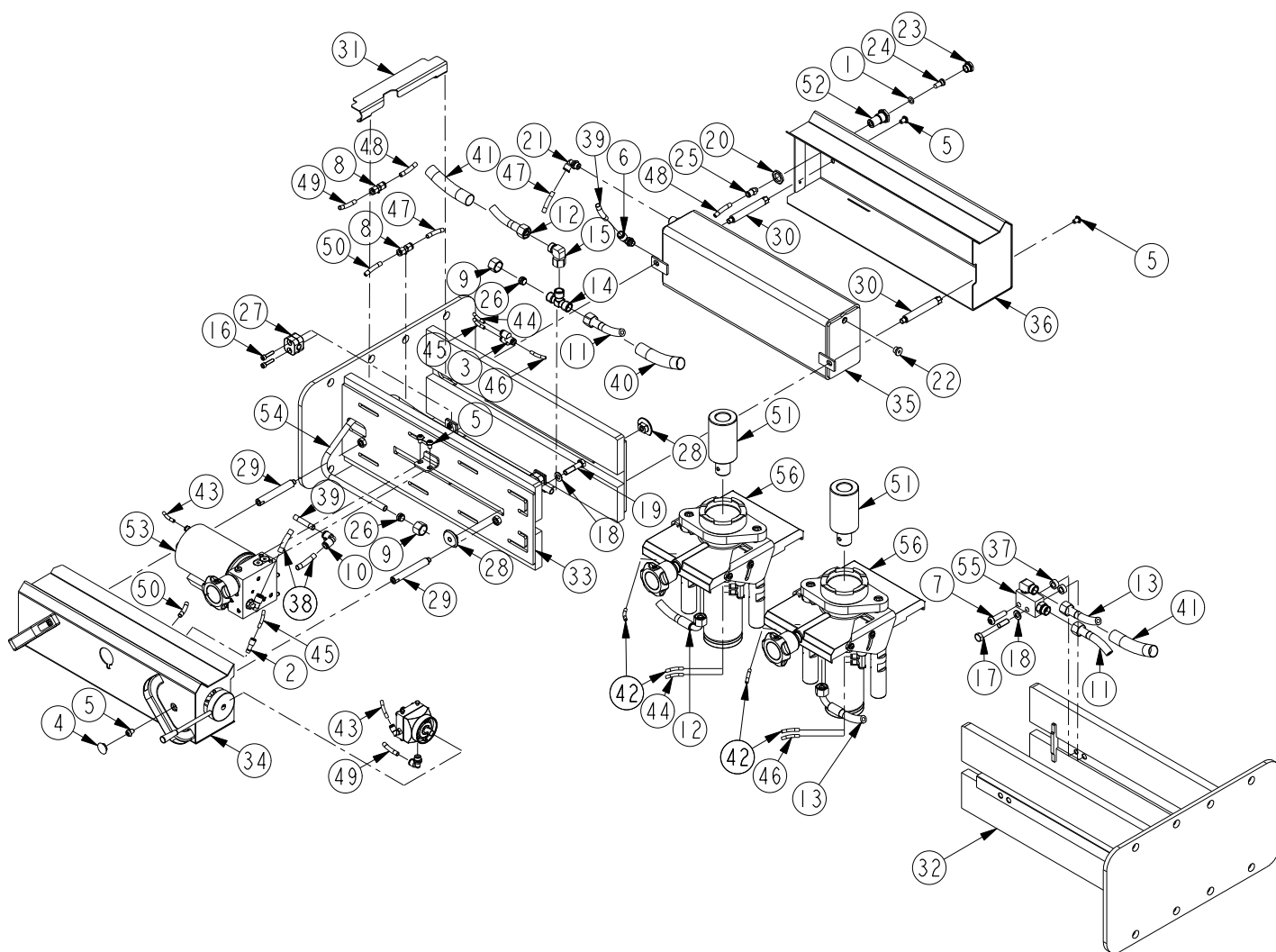
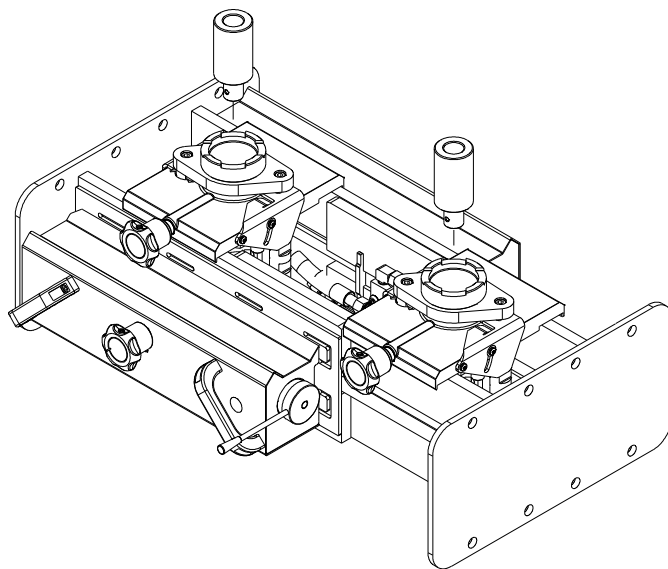

	FL-2MK	FL-2ML	FL-2MW		(DK)	(GB)	(DE)
Pos.	Art. No.	Art. No.	Art. No.	Pcs.	Benævnelse	Description	Bezeichnung
	58 763 xx	58 773 xx	58 783 xx		Frihjulsløfter	Jacking beam	Achsfreiheber
1	01 000 00	01 000 00	01 000 00	1	O-ring	O-ring	O-Ring
2	02 000 37	02 000 37	02 000 37	1	Fitting	Fitting	Fitting
3	02 000 42	02 000 42	02 000 42	1	Fitting	Fitting	Fitting
4	02 001 30	02 001 30	02 001 30	2	Prop	Plug	Pfropfen
5	02 001 43	02 001 43	02 001 43	6	Skruer	Screw	Schraube
6	02 002 49	02 002 49	02 002 49	1	Fitting	Fitting	Fitting
7	02 002 51	02 002 51	02 002 51	1	Skruer	Screw	Schraube
8	02 002 61	02 002 61	02 002 61	2	Fitting	Fitting	Fitting
9	02 002 84	02 002 84	02 002 84	2	Omløber	Union nut	Überwurfmutter
10	02 002 86	02 002 86	02 002 86	1	Fitting	Fitting	Fitting
11	02 005 36	02 005 36	02 005 36	1	Hydraulikslange	Hose	Schlauch
12	02 005 37	02 005 38	02 005 39	1	Hydraulikslange	Hose	Schlauch
13	02 005 37	02 005 38	02 005 39	1	Hydraulikslange	Hose	Schlauch
14	02 005 44	02 005 44	02 005 44	1	Fitting	Fitting	Fitting
15	02 005 45	02 005 45	02 005 45	1	Fitting	Fitting	Fitting
16	02 084 00	02 084 00	02 084 00	4	Skruer	Screw	Schraube
17	02 092 00	02 002 51	02 002 51	1	Skruer	Screw	Schraube
18	02 116 00	02 116 00	02 116 00	2/2/4	Skive	Washer	Scheibe
19	02 268 00	02 268 00	02 268 00	1/2/4	Skruer	Screw	Schraube
20	02 436 00	02 436 00	02 436 00	1	Møtrik	Nut	Mutter
21	02 439 00	02 439 00	02 439 00	1	Fitting	Fitting	Fitting
22	02 470 00	02 470 00	02 470 00	1	Prop	Plug	Pfropfen
23	02 506 00	02 506 00	02 506 00	1	Fitting	Fitting	Fitting
24	02 511 00	02 511 00	02 511 00	1	Filter	Filter	Filter
25	02 516 00	02 516 00	02 516 00	1	Fitting	Fitting	Fitting
26	02 752 00	02 752 00	02 752 00	2	Skæring	Ring	Ring
27	02 857 00	02 857 00	02 857 00	2	Rørholder	Clamp	Rohrhalter
28	58 630 02	58 630 02	58 630 02	2	Bøsning	Bush	Buchse
29	58 630 05	58 630 05	58 630 05	2	Støttebolt	Stud	Stehbolzen
30	58 630 06	58 630 06	58 630 06	2	Støttebolt	Stud	Stehbolzen
31	58 630 28	58 630 28	58 630 28	1	Skærm	Cover	Schirm
32	58 631 10	58 632 10	58 633 10	1	Inderkonsol	Console, inner	Haupttrahmen, innen
33	58 631 20	58 632 20	58 633 20	1	Yderkonsol	Console, outer	Haupttrahmen, aussen
34	58 651 10	58 651 10	58 651 10	1	Betjeningspanel	Operation panel	Bedienfeld
35	58 652 15	58 652 15	58 652 15	1	Olietank	Reservoir	Ölbehälter
36	58 653 10	58 653 10	58 653 10	1	Tankpanel	Cover, rear	Schirm, hinter
37	62 314 10	62 314 10	62 314 10	2	Afstandsbøsning	Distancebushing	Swishenrohr
38	90 791 07	90 791 07	90 791 07	1	Luftslange	Hose	Schlauch
39	90 791 65	90 791 65	90 791 65	1	Luftslange	Hose	Schlauch
40	90 792 50	90 792 50	90 792 50	1	Strømpeflex	Hose stocking	Strumpf
41	90 792 50	90 792 65	90 792 80	2	Strømpeflex	Hose stocking	Strumpf
42	90 796 18	90 796 18	90 796 18	2	Luftslange	Hose	Schlauch
43	90 796 70	90 796 70	90 796 70	1	Luftslange	Hose	Schlauch
44	90 796 75	90 797 00	90 797 05	1	Luftslange	Hose	Schlauch
45	90 796 90	90 797 00	90 797 13	1	Luftslange	Hose	Schlauch
46	90 797 20	90 797 20	90 797 20	1	Luftslange	Hose	Schlauch
47	90 798 12	90 798 12	90 798 12	1	Luftslange	Hose	Schlauch
48	90 798 26	90 798 26	90 798 26	1	Luftslange	Hose	Schlauch
49	90 798 60	90 798 60	90 798 60	1	Luftslange	Hose	Schlauch
50	90 798 67	90 798 67	90 798 67	1	Luftslange	Hose	Schlauch
51	91 141 00	91 141 00	91 141 00	2	Forlænger	Extension	Verlängerung
52	91 206 00	91 206 00	91 206 00	1	Filterhus	Filtercasing	Gehäuse für Filter
53	91 605 xx	91 605 xx	91 605 xx	1	Pumpe, kpl.	Pump, complete	Pumpe, komplett
54	91 605 06	91 605 05	91 605 12	1	Hydraulikrør	Tube	Rohr
55	91 605 10	91 605 10	91 605 10	1	Manifold	Manifold	Verteiler
56	91 606 00	91 606 00	91 606 00	2	Cylinder, kpl.	Cylinder, complete	Zylinder, komplett

DK: Anvend altid originale reservedele. Angiv venligst altid model og reservedelsnummer. Alle hoveddele kan ikke forventes leveret efter produktionsophør.

GB: Please always state model and part number. Do always apply original spare parts.

All major parts may not be provided as spare parts after discontinuation of production of a model.

DE: Bitte immer Modell und Ersatzteilnummer auf Ihren Bestellungen angeben. Immer nur Originalteile verwenden. Lieferung von allen Hauptteilen als Ersatzteile kann nach Produktions-Einstellung eines Modelles nicht erwartet werden.

58 651 10

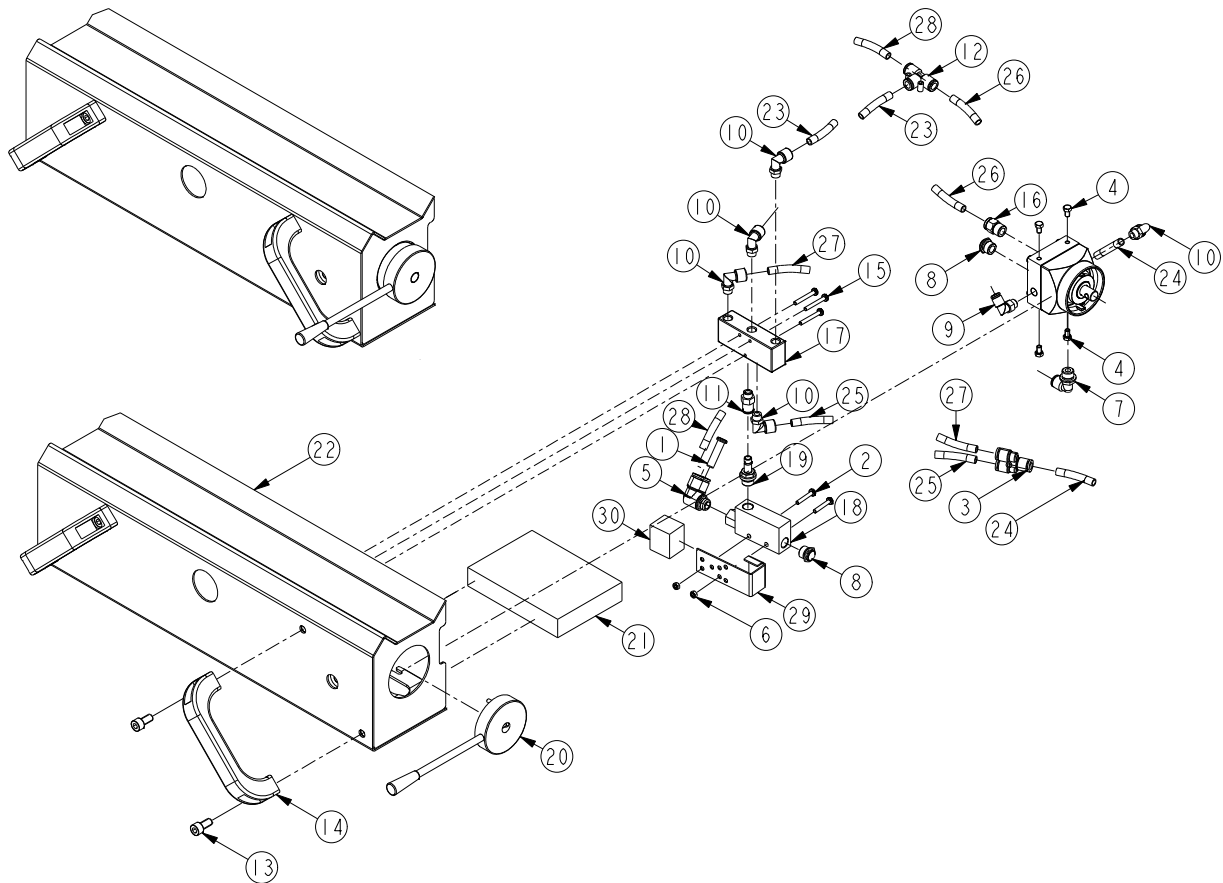

Pos.	GD-2 Art. No.	FL-2 Art. No.	Pcs.	(DK) Benævnelse	(GB) Description	(DE) Bezeichnung
	58 651 10	58 651 10		Betjeningspanel	Operation panel	Bedienfeld
1	02 000 10	02 000 10	1	Prop	Plug	Pfropfen
2	02 000 40	02 000 40	2	Skruer	Screw	Schraube
3	02 002 33	02 002 33	1	Fitting	Fitting	Fitting
4	02 002 34	02 002 34	4	Skruer	Screw	Schraube
5	02 005 32	02 005 32	1	Fitting	Fitting	Fitting
6	02 017 00	02 017 00	2	Møtrik	Nut	Mutter
7	02 439 00	02 439 00	1	Fitting	Fitting	Fitting
8	02 481 00	02 481 00	2	Lyddæmper	Sound absorber	Schalldämpfer
9	02 493 00	02 493 00	1	Fitting	Fitting	Fitting
10	02 495 00	02 495 00	5	Fitting	Fitting	Fitting
11	02 516 00	02 516 00	1	Fitting	Fitting	Fitting
12	02 530 00	02 530 00	1	Fitting	Fitting	Fitting
13	02 551 00	02 551 00	4	Skruer	Screw	Schraube
14	02 738 00	02 738 00	2	Håndtag	Handle	Handgriff
15	02 763 00	02 763 00	3	Skruer	Screw	Schraube
16	02 770 00	02 770 00	1	Fitting	Fitting	Fitting
17	02 773 00	02 773 00	1	Skifteventil	Changevalve	Wechselventil
18	02 774 00	02 774 00	1	Vakuumpumpe	Vacuum pump	Vakuumpumpe
19	02 844 00	02 844 00	1	Fitting	Fitting	Fitting
20	42 030 00	42 030 00	1	Betjeningsventil	Controlvalve	Steuventil
21	44 015 00	44 015 00	1	Lyddæmper	Sound absorber	Schalldämpfer
22	58 650 07	58 650 07	1	Frontpanel	Operation panel	Bedienfeld
23	90 798 04	90 798 04	1	Luftslange	Air hose	Luftschlauch
24	90 798 07	90 798 07	1	Luftslange	Air hose	Luftschlauch
25	90 798 07	90 798 07	1	Luftslange	Air hose	Luftschlauch
26	90 798 08	90 798 08	1	Luftslange	Air hose	Luftschlauch
27	90 798 13	90 798 13	1	Luftslange	Air hose	Luftschlauch
28	90 798 16	90 798 16	1	Luftslange	Air hose	Luftschlauch
29	91 270 37	91 270 37	1	Lyddæmperssvøb	Sound abs. case	Schalldämpfer Hölse
30	91 270 39	91 270 39	1	Lyddæmpersvamp	Sound abs. mat.	Schalldämpfer

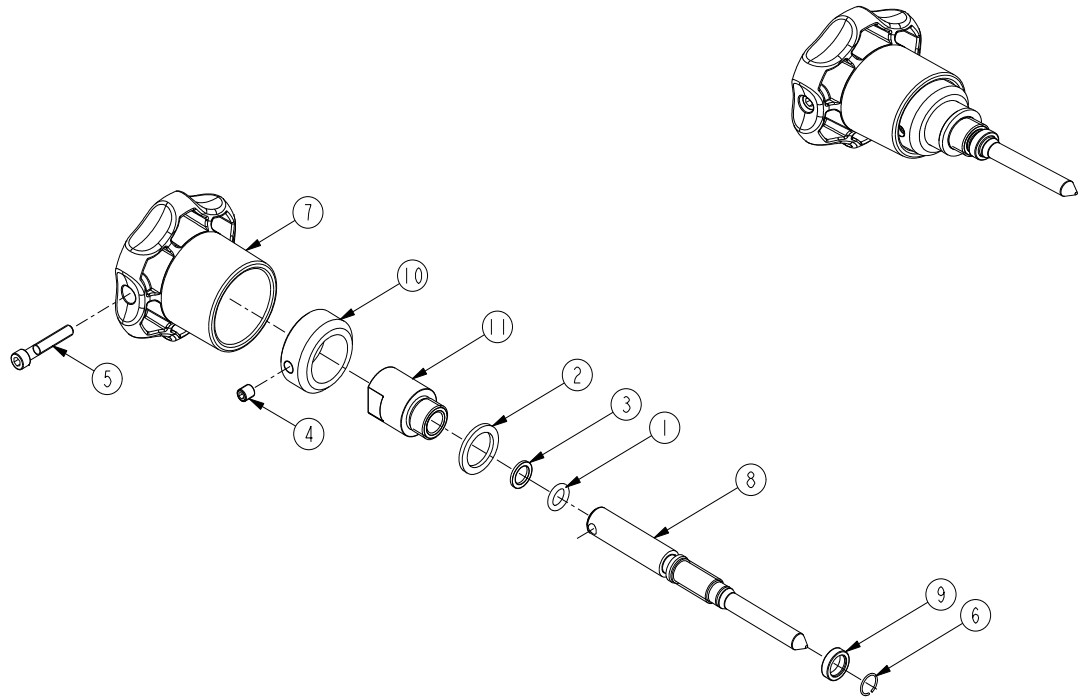

Pos.	GD-2 Art. No.	FL-2 Art. No.	Pcs.	(DK) Benævnelse	(GB) Description	(DE) Bezeichnung
	91 121 00	91 121 00		Afspæringsventil	Lock valve	Absperrventil
*1	01 086 00	01 086 00	1	O-ring	O-ring	O-ring
*2	01 244 00	01 244 00	1	Pakning	Seal	Dichtung
*3	01 364 00	01 364 00	1	Støttering	Back-up ring	Stützring
4	02 301 00	02 301 00	1	Pinolskrue	Pinol screw	Schraube
5	02 324 00	02 324 00	1	Skrue	Screw	Schraube
6	02 996 00	02 996 00	1	Springring	Spring ring	Klemmring
7	62 016 00	62 016 00	1	Udløsergreb	Release handle	Betätigungsgriff
8	91 120 00	91 120 00	1	Ventilspindel	Valve spindle	Ventilspindel
9	91 120 01	91 120 01	1	Låseskive	Lock washer	Arretierscheibe
10	91 124 00	91 124 00	1	Fjederholder	Spring attachment	Federaufhängung
11	91 140 00	91 140 00	1	Spindelhus	Spindle housing	Spindelgehäuse
*	09 087 00	09 087 00		Pakningssæt	Repair kit	Dichtungssatz

DK: De med * mærkede dele leveres i komplet pakningssæt. Anvend altid originale reservedele. Angiv venligst altid model og reservedelsnummer. Alle hoveddele kan ikke forventes leveret efter produktionsophør af model.

GB: * indicate parts included in repair set. Please always state model and part number. Do always apply original spare parts.

All major parts may not be provided as spare parts after discontinuation of production of a model.

DE: Die mit * markierten Teile sind im Dichtungssatz enthalten. Bitte immer Modell und Ersatzteilnummer auf Ihren Bestellungen angeben. Immer nur Originalteile verwenden. Lieferung von allen Hauptteilen als Ersatzteile kann nach Produktions-Einstellung eines Modelles nicht erwartet werden.

91 603 00
91 604 00

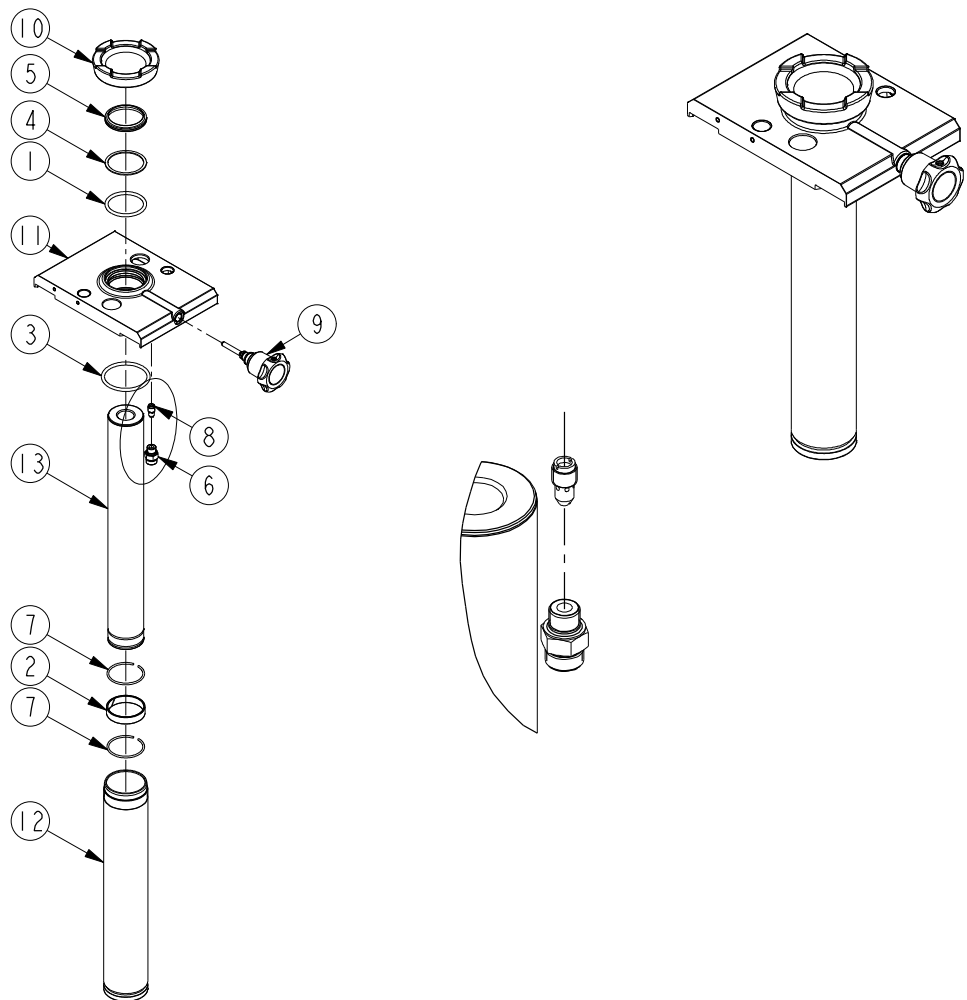

	GD-2	FL-2		(DK)	(GB)	(DE)
Pos.	Art. No.	Art. No.	Pcs.	Benævnelse	Description	Bezeichnung
	91 604 00	91 603 00		Cylinder, komplet	Cylinder, complete	Zylinder, komplett
*1	01 001 03	01 001 03	1	O-ring	O-ring	O-Ring
*2	01 001 04		1	Styrering	Wear ring	Verschleißring
*3	01 078 00	01 078 00	1	O-ring	O-ring	O-Ring
*4	01 155 00	01 155 00	1	Støttering	Buck-up ring	Stützring
5	01 272 00	01 272 00	1	Afstryger	Scraper ring	Abstreifer
6	02 005 43	02 005 43	1	Fitting	Fitting	Fitting
7	02 679 00	02 679 00	2/1	Springring	Springring	Feder Ring
8	02 839 00	02 839 00	1	Sænke-bremseventil	Brake valve	Bremseventil
9	91 121 00	91 121 00	1	Afspærringsventil	Lock valve	Absperrventil
10	91 144 00	91 144 00	1	Sadel	Saddle	Sattel
11	91 601 03	91 601 03	1	Cylinderflange	Flange	Flansch
12	91 604 01	91 603 01	1	Cylinderrør	Cylinder	Zylinder
13	91 604 03	91 603 03	1	Stok	Piston rod	Kolbenstange
*	09 087 00	09 087 00		Pakningsæt, cyl.	Seal kit, cylinder	Dichtungssatz, Zyl.

DK: De med * mærkede dele leveres i komplet pakningsæt. Anvend altid originale reservedele. Angiv venligst altid model og reservedelsnummer. Alle hoveddele kan ikke forventes leveret efter produktionsophør af model.

GB: * indicate parts included in repair set. Please always state model and part number. Do always apply original spare parts. All major parts may not be provided as spare parts after discontinuation of production of a model.

DE: Die mit * markierten Teile sind im Dichtungssatz enthalten. Bitte immer Modell und Ersatzteilnummer auf Ihren Bestellungen angeben. Immer nur Originalteile verwenden. Lieferung von allen Hauptteilen als Ersatzteile kann nach Produktions-Einstellung eines Modelles nicht erwartet werden.

91 606 00
91 607 00

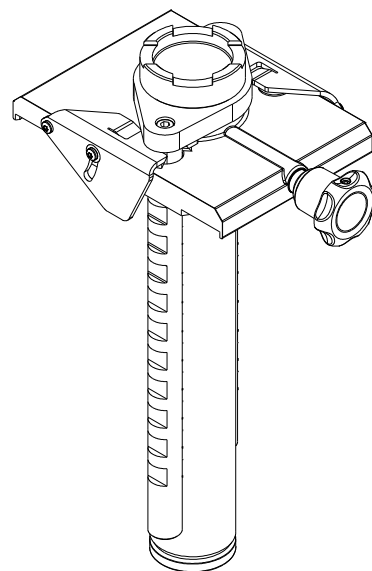
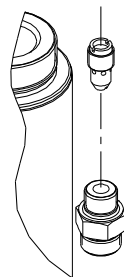
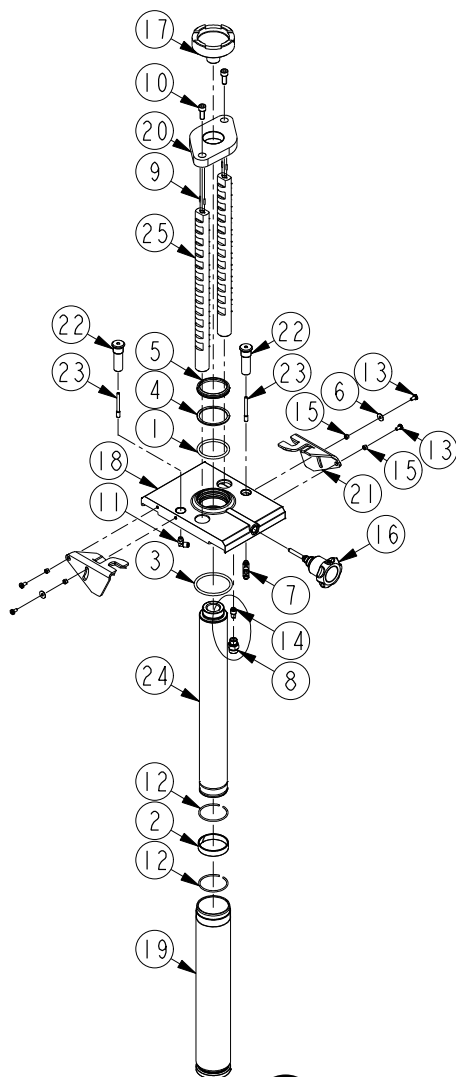

	GD-2M	FL-2M		(DK)	(GB)	(DE)
Pos.	Art. No.	Art. No.	Pcs.	Benævnelse	Description	Bezeichnung
	91 607 00	91 606 00		Cylinder, komplet	Cylinder, complete	Zylinder, komplett
*1	01 001 03	01 001 03	1	O-ring	O-ring	O-Ring
*2	01 001 04		1	Styrering	Wear ring	Verschleißring
*3	01 078 00	01 078 00	1	O-ring	O-ring	O-Ring
*4	01 155 00	01 155 00	1	Støttering	Buck-up ring	Stützring
*5	01 272 00	01 272 00	1	Afstryger	Scraper ring	Abstreifer
6	02 003 66	02 003 66	2	Skive	Washer	Scheibe
7	02 005 27	02 005 27	1	Fitting	Fitting	Fitting
8	02 005 43	02 005 43	1	Fitting	Fitting	Fitting
9	02 277 00	02 277 00	4	Kærvstift	Tack	Stift
10	02 305 00	02 305 00	2	Skrue	Screw	Schraube
11	02 493 00	02 493 00	1	Fitting	Fitting	Fitting
12	02 679 00	02 679 00	2/1	Springring	Springring	Feder Ring
13	02 781 00	02 781 00	4	Skrue	Screw	Schraube
14	02 839 00	02 839 00	1	Sænke-bremseventil	Brake valve	Bremseventil
15	62 473 04	62 473 04	4	Bøsning	Bush	Buchse
16	91 121 00	91 121 00	1	Afspærringsventil	Lock valve	Absperrventil
17	91 132 30	91 132 30	1	Sadel	Saddle	Sattel
18	91 601 03	91 601 03	1	Cylinderflange	Flange	Flansch
19	91 604 01	91 603 01	1	Cylinderrør	Cylinder	Zylinder
20	91 606 03	91 606 03	1	Sikringsåg	Top beam	Joch
21	91 606 06	91 606 06	2	Låsebeslag	Lock	Verschlussvorrichtung
22	91 606 10	91 606 10	2	Cylinderhus	Cylinder	Zylinder
23	91 606 11	91 606 11	2	Stok	Ram	Kolbenstange
24	91 607 02	91 606 02	1	Stok	Ram	Kolbenstange
25	91 607 05	91 606 05	2	Tandstang	Toothed bar	Zahnstange
*	09 087 00	09 087 00		Pakningsæt, cyl.	Seal kit, cylinder	Dichtungssatz, Zyl.

91 605 XX

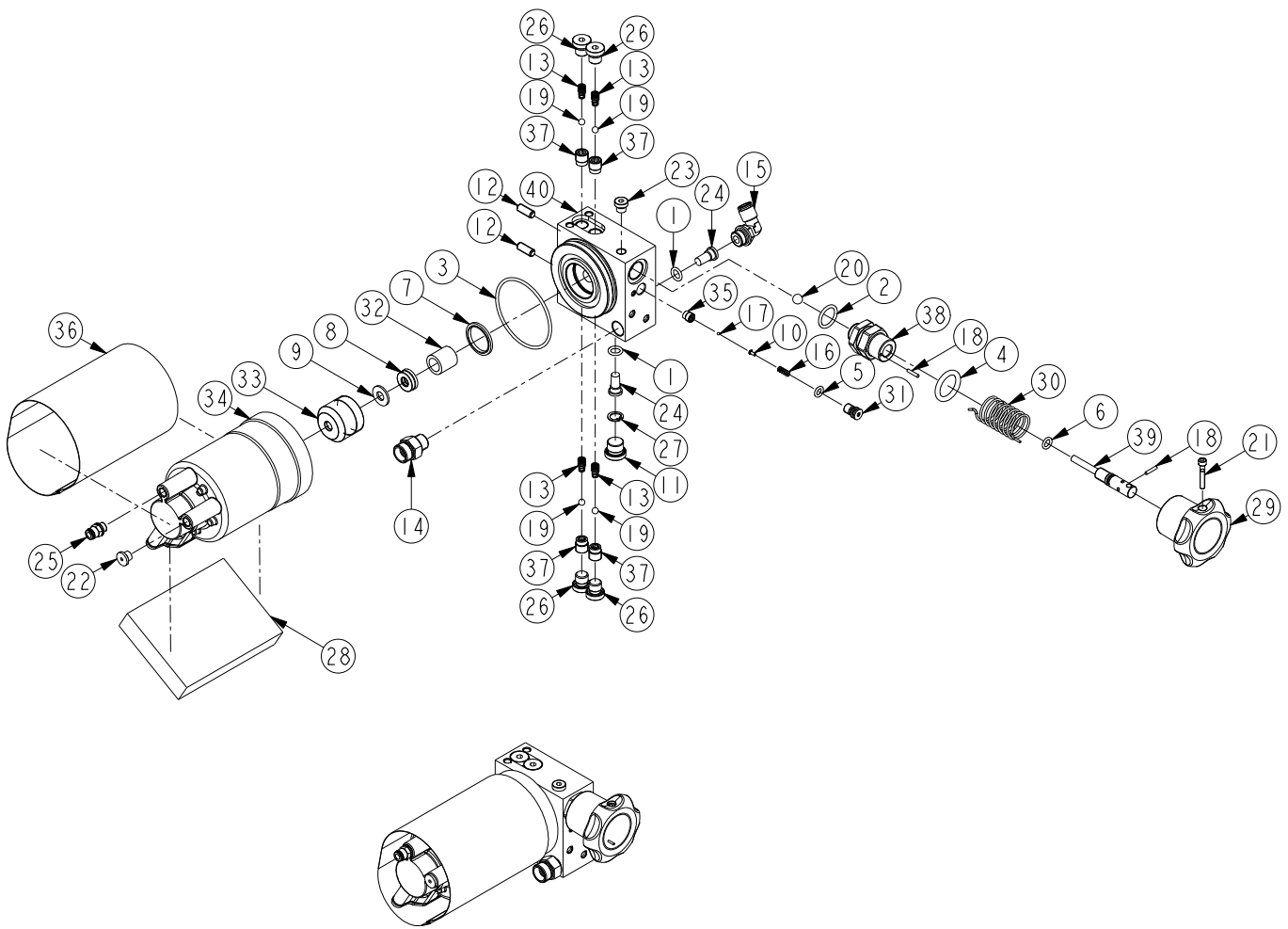

90 728 40

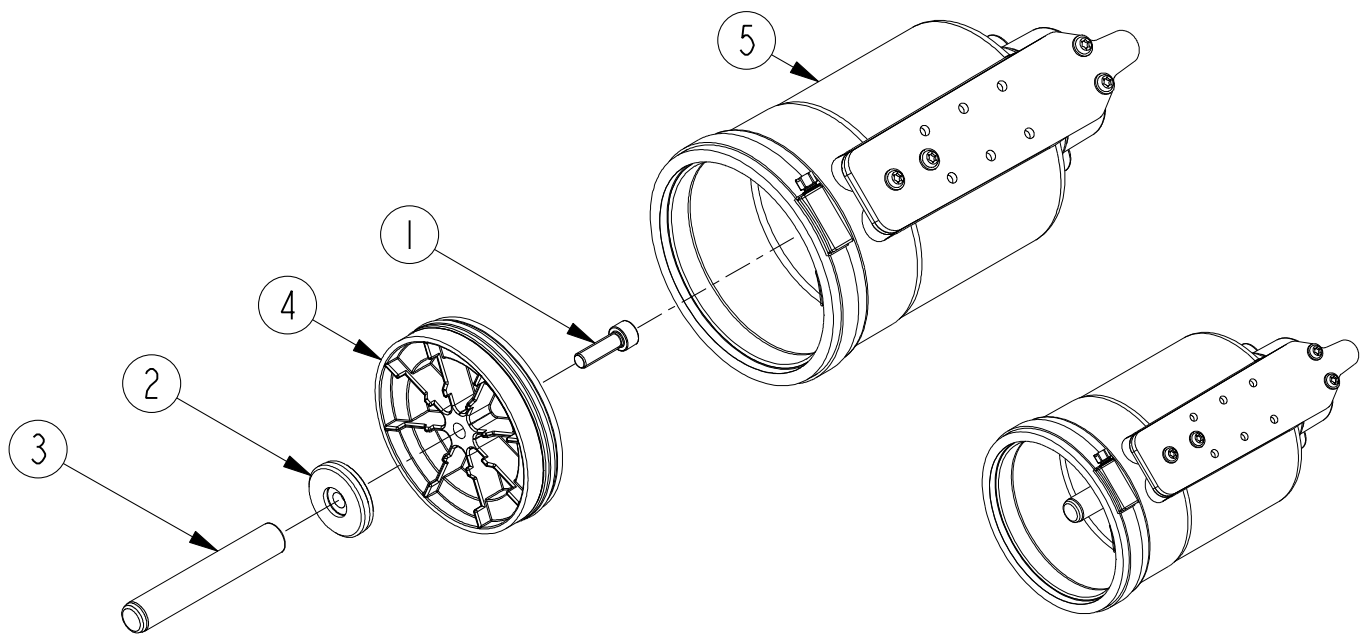

Pos.	GD-2	FL-2	Pcs.	(DK)	(GB)	(DE)
	Art. No.	Art. No.		Benævnelse	Description	Bezeichnung
	91 605 xx	91 605 xx		Pumpe, komplet	Pump, complete	Pumpe, komplett
*1	01 000 00	01 000 00	2	O-ring	O-ring	O-Ring
*2	01 003 00	01 003 00	1	O-ring	O-ring	O-Ring
*3	01 007 00	01 007 00	1	O-ring	O-ring	O-Ring
*4	01 045 00	01 045 00	1	O-ring	O-ring	O-Ring
*5	01 057 00	01 057 00	1	O-ring	O-ring	O-Ring
*6	01 086 00	01 086 00	1	O-ring	O-ring	O-Ring
*7	01 245 00	01 245 00	1	Pakning	Seal	Dichtung
*8	01 629 00	01 629 00	1	Nutring	Seal	Dichtung
*9	01 631 00	01 631 00	1	Støttering	Support ring	Stützring
10	02 000 22	02 000 22	1	Skruer	Screw	Schraube
11	02 000 77	02 000 77	1	Prop	Plug	Pfropfen
12	02 001 62	02 001 62	2	Pinolskrue	Screw	Schraube
13	02 004 40	02 004 40	4	Fjeder	Spring	Feder
14	02 005 43	02 005 43	1	Fitting	Fitting	Fitting
15	02 005 97	02 005 97	1	Fitting	Fitting	Fitting
16	02 078 00	02 078 00	1	Fjeder	Spring	Feder
*17	02 183 00	02 183 00	1	Kugle, Ø2,5	Ball, Ø2,5	Kugel, Ø2,5
18	02 277 00	02 277 00	2	Kærvstift	Tack	Stift
*19	02 292 00	02 292 00	4	Kugle, Ø6,5	Ball, Ø6,5	Kugel, Ø6,5
*20	02 294 00	02 294 00	1	Kugle, Ø10	Ball, Ø10	Kugel, Ø10
21	02 324 00	02 324 00	1	Skruer	Screw	Schraube
22	02 448 00	02 448 00	1	Prop	Plug	Pfropfen
23	02 483 00	02 483 00	1	Prop	Plug	Pfropfen
*24	02 511 00	02 511 00	2	Filter	Filter	Filter
25	02 512 00	02 512 00	1	Fitting	Fitting	Fitting
26	02 584 00	02 584 00	4	Prop	Plug	Pfropfen
27	02 931 00	02 931 00	1	Seegerring	Circlip	Seegerring
28	44 015 00	44 015 00	1	Lyddæmpermat.	Sound absorber	Schalldämpfer
29	62 016 00	62 016 00	1	Udløsergreb	Release handle	Betätigungsgriff
30	90 624 00	90 624 00	1	Fjeder	Spring	Feder
31	90 674 00	90 674 00	1	Justerskrue	Adjusting screw	Justierschraube
32	90 704 00	90 704 00	1	Afstandsøsning	Distance bushing	Abstandhülze
33	90 707 10	90 707 10	1	Pakboks	Packing box	Pakmutter
34	90 728 40	90 728 40	1	Luftmotor	Air motor	Luftmotor
*35	90 744 00	90 744 00	1	Ventilindsats 1/8"RG Ø2	Valve cartridge	Ventileinsatz
36	90 814 00	90 814 00	1	Lyddæmpersvøb	Sound ab. case	Schalldämpfer Hölse
*37	91 128 00	91 128 00	4	Ventilindsats 1/4"RG Ø5	Valve cartridge	Ventileinsatz
38	91 605 03	91 605 03	1	Spindelhus	Spindle box	Spindel Gehäuse
39	91 605 04	91 605 04	1	Ventilspindel	Spindle	Spindel
40	91 605 20	91 605 20	1	Pumpeblok	Pump block	Pumpenblock
*	09 077 00	09 077 00		Pakningssæt	Repair kit	Dichtungssatz

Pos.	GD-2	FL-2	Pcs.	(DK)	(GB)	(DE)
	Art. No.	Art. No.		Benævnelse	Description	Bezeichnung
	90 728 40	90 728 40		Luftmotor	Air motor	Luftmotor
1	02 347 00	02 347 00	1	Skruer	Screw	Schraube
2	90 267 02	90 267 02	1	Støtteskive	Back-up ring	Stützscheibe
3	90 267 10	90 267 10	1	Pumpestempel	Pump piston	Pumpkolben
4	90 268 00	90 268 00	1	Luftstempel	Air piston	Luftkolben
5	90 709 04	90 709 04	1	Luftcylinder	Air cylinder	Luftzylinder

DK: De med * mærkede dele leveres i komplet pakningssæt. Anvend altid originale reservedele. Angiv venligst altid model og reservedelsnummer. Alle hoveddele kan ikke forventes leveret efter produktionsophør af model.

GB: * indicate parts included in repair set. Please always state model and part number. Do always apply original spare parts. All major parts may not be provided as spare parts after discontinuation of production of a model.

DE: Die mit * markierten Teile sind im Dichtungssatz enthalten. Bitte immer Modell und Ersatzteilnummer auf Ihren Bestellungen angeben. Immer nur Originalteile verwenden. Lieferung von allen Hauptteilen als Ersatzteile kann nach Produktions-Einstellung eines Modelles nicht erwartet werden.

(DK) **HYDRAULIK DIAGRAM**
 (GB) **HYDRAULIC CHART**
 (DE) **HYDRAULISCHES DIAGRAMM**

FL-2
GD-2

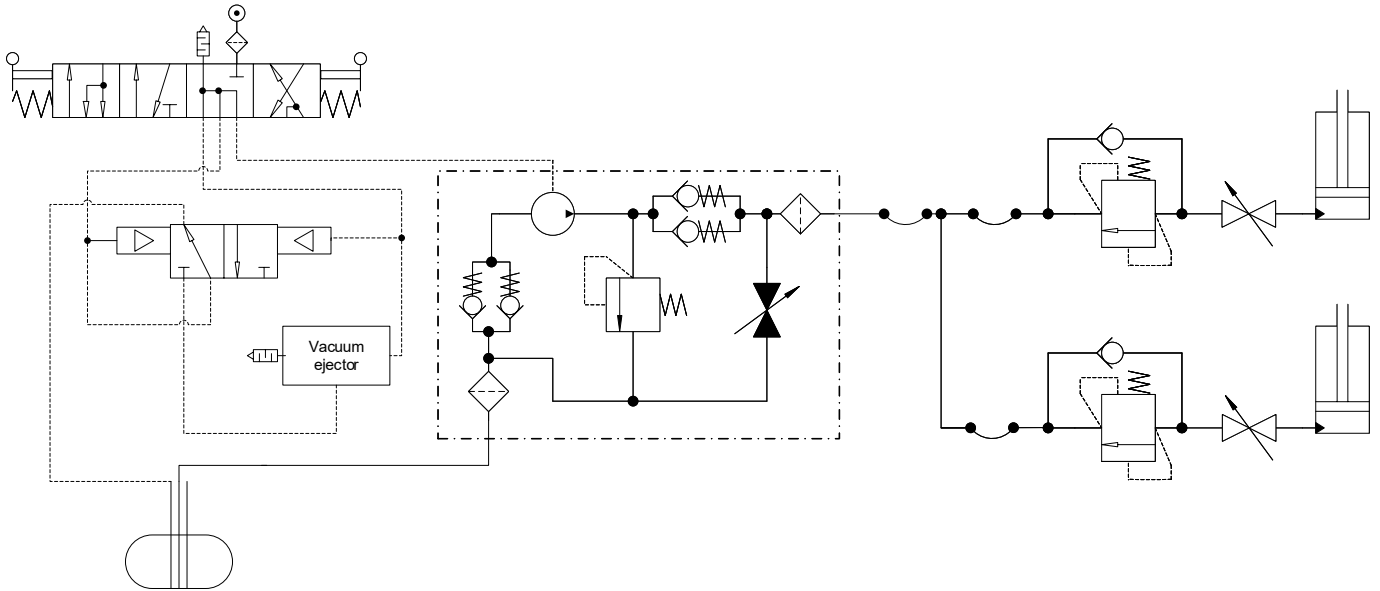

FL-2M
GD-2M

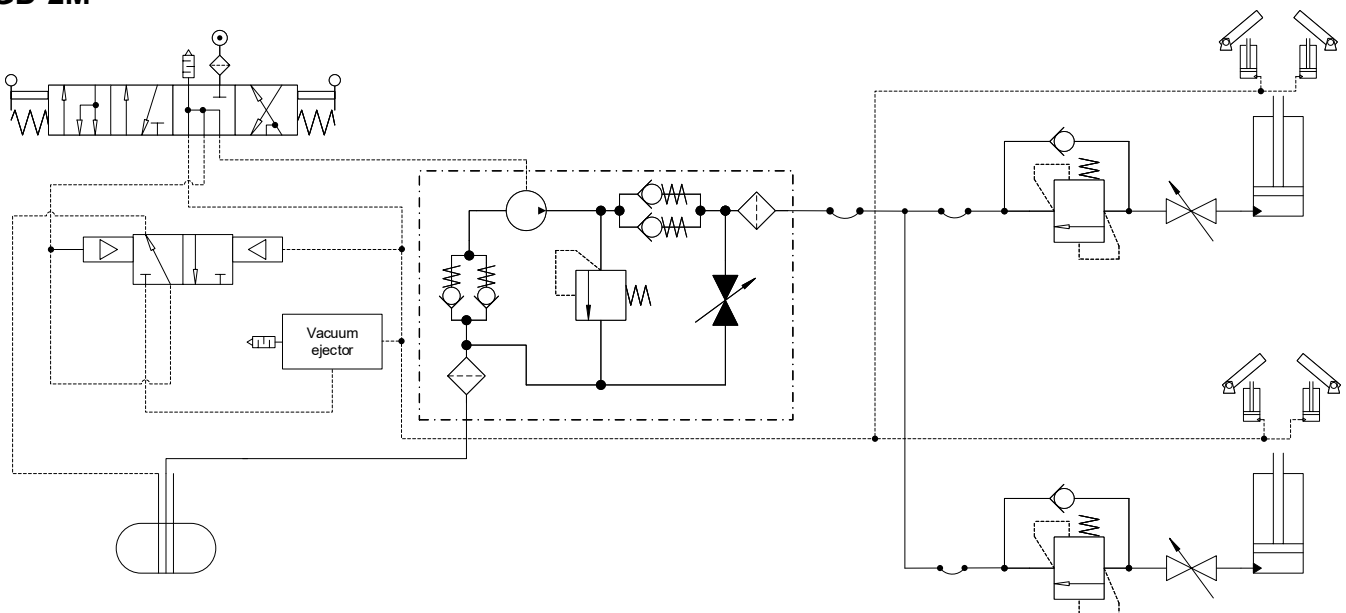

DK **TILBEHØR**
GB **ACCESSORIES**
DE **ZUBEHÖR**

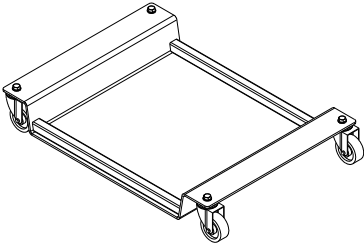

FL
Art. No. 58 367 00 **Pcs.** 1 **Benævnelse** Kørevogn

GB
Description
 Practical trolley

DE
Bezeichnung
 Fahrwagen

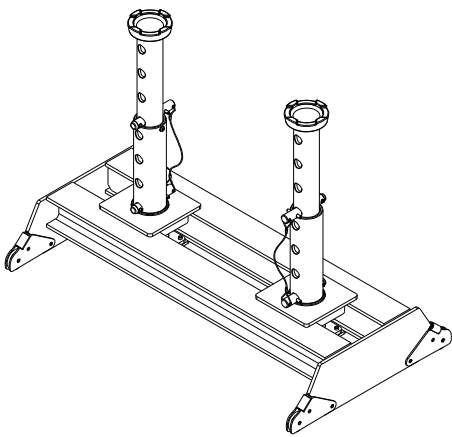

GD
Art. No. 58 670 10 **Pcs.** 1 **Benævnelse** Aflastningsbro

GB
Description
 Support bridge

DE
Bezeichnung
 Abstützbrücke

(20.000 kg)

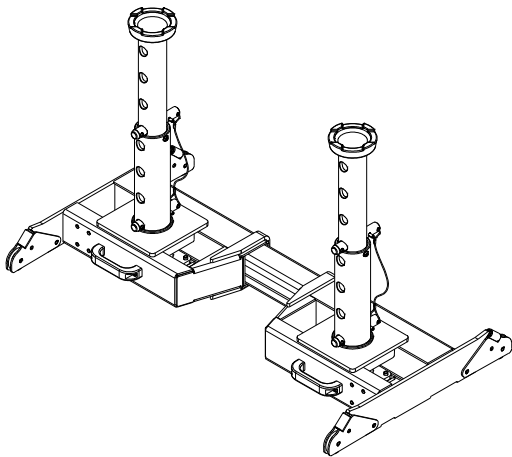

DK
Pcs. 1 **Benævnelse** Aflastningsbro
 10 1 Aflastningsbro, lang

GB
Description
 Support bridge
 Support bridge, long

DE
Bezeichnung
 Abstützbrücke
 Abstützbrücke, lang

100 kg)

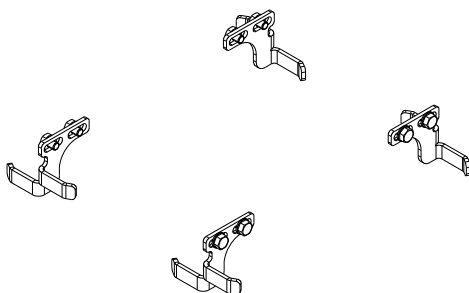

GD
Art. No. 58 675 50 **Pcs.** 4 **Benævnelse** Afspring

GB
Description
 Rail guides

DE
Bezeichnung
 Seitenführung

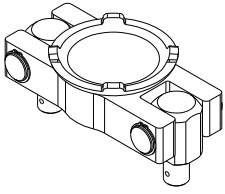

GD/FL **(DK)**
Art. No. Pcs. Benævnelse
91 143 00 1 Løftebro

(GB)
Description
Diff beam

(DE)
Bezeichnung
Hebebrücke

(20.000 kg)

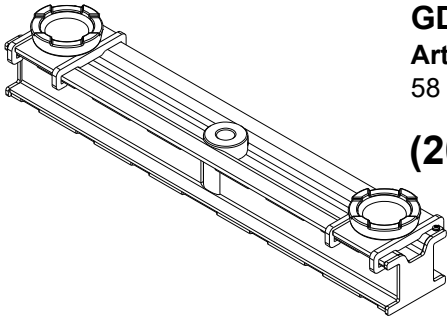

GD/FL **(DK)**
Art. No. Pcs. Benævnelse
58 660 00 1 Travers

(GB)
Description
Cross beam adaptor

(DE)
Bezeichnung
Achstraverse

(20.000 kg)

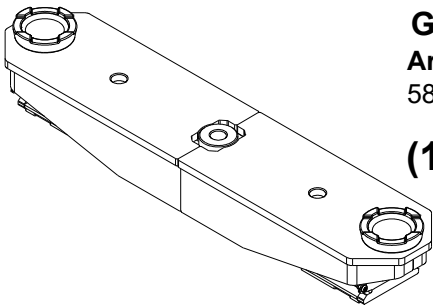

GD/FL **(DK)**
Art. No. Pcs. Benævnelse
58 668 00 1 Travers

(GB)
Description
Cross beam adaptor

(DE)
Bezeichnung
Achstraverse

(15.000-11.500 kg)

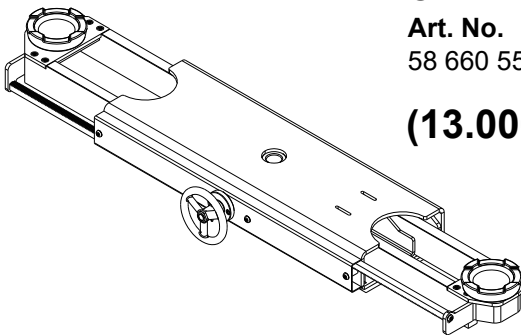

GD/FL **(DK)**
Art. No. Pcs. Benævnelse
58 660 55 1 Travers

(GB)
Description
Cross beam adaptor

(DE)
Bezeichnung
Achstraverse

(13.000 kg)

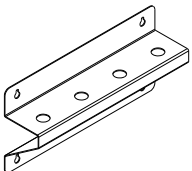

GD/FL **(DK)**
Art. No. Pcs. Benævnelse
58 663 40 1 Vægbeslag

(GB)
Description
Wall bracket

(DE)
Bezeichnung
Wandhalterung

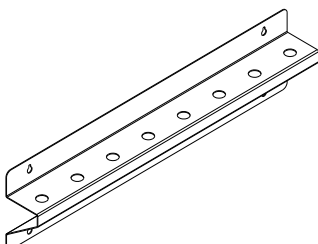

GD/FL **(DK)**
Art. No. Pcs. Benævnelse
58 663 80 1 Vægbeslag

(GB)
Description
Wall bracket

(DE)
Bezeichnung
Wandhalterung

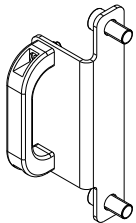

GD/FL		(DK)	(GB)	(DE)
Art. No.	Pcs.	Benævnelse	Description	Bezeichnung
58 634 00	1	Greb	Handle	Griff

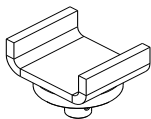

GD/FL				
Art. No.	Pcs.	Benævnelse	Description	Bezeichnung
91 132 10	1	U-Sadel	U-Saddle	U-Sattel
(10.000 kg)				

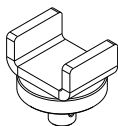

GD/FL (ANSI/ALI approved)				
Art. No.	Pcs.	Benævnelse	Description	Bezeichnung
91 132 20	1	U-Sadel	U-Saddle	U-Sattel
(10.000 kg)				

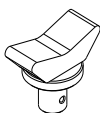

GD/FL				
Art. No.	Pcs.	Benævnelse	Description	Bezeichnung
91 127 00	1	V-Sadel	V-Saddle	V-Sattel
(10.000 kg)				

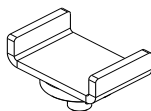

GD/FL		(DK)	(GB)	(DE)
Art. No.	Pcs.	Benævnelse	Description	Bezeichnung
91 132 40	1	U-Sadel	U-Saddle	U-Sattel
(10.000 kg) (ANSI/ALI 6000 kg)				

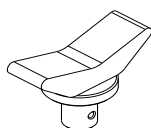

GD/FL		(DK)	(GB)	(DE)
Art. No.	Pcs.	Benævnelse	Description	Bezeichnung
91 127 10	1	V-Sadel	V-Saddle	V-Sattel
(10.000 kg) (ANSI/ALI 4000 kg)				

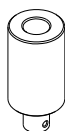

GD/FL (ANSI/ALI approved)				
Art. No.	Pcs.	Benævnelse	Description	Bezeichnung
91 141 00	1	Forlænger 100 mm	Extension 100 mm	Verlängerung 100 mm
(10.000 kg)				



GD/FL (ANSI/ALI approved)				
Art. No.	Pcs.	Benævnelse	Description	Bezeichnung
91 142 00	1	Forlænger 200 mm	Extension 200 mm	Verlängerung 200 mm
(10.000 kg)				

(DK) 91 142 00 - må **ikke** anvendes sammen med andre forlængere!!

(GB) 91 142 00 - may **not** be used with other extensions!!

(DE) 91 142 00 - darf **nicht** mit anderen Verlängerungen benutzt werden!!

EU Overensstemmelseserklæring
EC Declaration of Conformity for Machinery
EG Konformitätserklärung
Declaration CE de conformité pour les composants
EU Vaatimustenmukaisuuvakuutus

EU Verklaring van overeenstemming
EU Declaración de conformidad sobre maquinaria
EU Överensstämelseforsäkran
ЕС декларации о соответствии
Dichiarazione di conformità UE

Directive 2006/42/EC

DK GD-2, FL-2

NO er i overensstemmelse med Maskindirektivets bestemmelser (Direktiv 2006/42/EC og EN1494).
Carsten Rødbro Jensen, Fanøvej 6, DK-8800 er bemyndiget til at udarbejde det tekniske dossier.

GB GD-2, FL-2

are in conformity with the provisions of the Machinery Directive (Directive 2006/42/EC and EN1494).
Mr. Carsten Rødbro Jensen, Fanøvej 6, DK-8800 is authorized to compile the technical file.

DE GD-2, FL-2

sind mit den einschlägigen Bestimmungen der EG-Maschinenrichtlinie 2006/42/EC und EN1494 konform.
Herr Carsten Rødbro Jensen, Fanøvej 6, DK-8800 ist berechtigt, die technischen Unterlagen zusammenzustellen.

FR GD-2, FL-2

sont conformes aux dispositions de la Directive Machine 2006/42/EC et EN1494.
Carsten Rødbro Jensen, Fanøvej 6, DK-8800 est autorisée à constituer le dossier technique.

FI GD-2, FL-2

vastaa Konedirektiivin (direktiivi 2006/42/EC ja EN1494).
Carsten Rødbro Jensen, Fanøvej 6, DK-8800 on valtuutettu kokoamaan teknisen tiedoston. määräyksiä sekä kansallista voimaantulolainsäädäntöä.

NL GD-2, FL-2

in overeenstemming zijn met de bepalingen van de Richtlijn Machines (richtlijn 2006/42/EC en EN1494).
Carsten Rødbro Jensen, Fanøvej 6, DK-8800 gemachtigd is om het technisch dossier samen te stellen.

ES GD-2, FL-2

son conforme a las directrices sobre maquinaria (Directiva 2006/42/EC y EN1494).
Carsten Rødbro Jensen, Fanøvej 6, DK-8800 está facultado para elaborar el expediente técnico.

SE GD-2, FL-2

Överensstämmer med Maskindirektivets bestämmelser (Direktiv 2006/42/EC och EN1494).
Carsten Rødbro Jensen, Fanøvej 6, DK-8800 är behörig att ställa samman den tekniska dokumentationen.

RU GD-2, FL-2

полностью соответствуют требованиям, предъявляемым Директивой на машины и механизмы (директива 2006/42/EC и EN1494).
Carsten Rødbro Jensen, Fanøvej 6, DK-8800 уполномочен составлять техническую документацию.

IT GD-2, FL-2

sono in conformità con le disposizioni della Direttiva macchine (Direttiva 2006/42/CE e EN 1494)
Carsten Rødbro Jensen, Fanøvej 6, DK-8800 è autorizzato a costituire il fascicolo tecnico.



AC Hydraulic A/S

Fanøvej 6
DK-8800 Viborg - Danmark
Tel.: +45 8662 2166
Fax: +45 8662 2988
E-mail: ac@ac-hydraulic.dk
www.ac-hydraulic.com

Carsten Rødbro Jensen
General Manager
Viborg 01.01.21

